

The University of the State of New York
REGENTS HIGH SCHOOL EXAMINATION

GEOMETRY

Wednesday, August 13, 2014 — 8:30 to 11:30 a.m., only

Student Name: Mr. Sibol

School Name: JMAP

The possession or use of any communications device is strictly prohibited when taking this examination. If you have or use any communications device, no matter how briefly, your examination will be invalidated and no score will be calculated for you.

Print your name and the name of your school on the lines above.

A separate answer sheet for Part I has been provided to you. Follow the instructions from the proctor for completing the student information on your answer sheet.

This examination has four parts, with a total of 38 questions. You must answer all questions in this examination. Record your answers to the Part I multiple-choice questions on the separate answer sheet. Write your answers to the questions in Parts II, III, and IV directly in this booklet. All work should be written in pen, except for graphs and drawings, which should be done in pencil. Clearly indicate the necessary steps, including appropriate formula substitutions, diagrams, graphs, charts, etc.

The formulas that you may need to answer some questions in this examination are found at the end of the examination. This sheet is perforated so you may remove it from this booklet.

Scrap paper is not permitted for any part of this examination, but you may use the blank spaces in this booklet as scrap paper. A perforated sheet of scrap graph paper is provided at the end of this booklet for any question for which graphing may be helpful but is not required. You may remove this sheet from this booklet. Any work done on this sheet of scrap graph paper will *not* be scored.

When you have completed the examination, you must sign the statement printed at the end of the answer sheet, indicating that you had no unlawful knowledge of the questions or answers prior to the examination and that you have neither given nor received assistance in answering any of the questions during the examination. Your answer sheet cannot be accepted if you fail to sign this declaration.

Notice...

A graphing calculator, a straightedge (ruler), and a compass must be available for you to use while taking this examination.

DO NOT OPEN THIS EXAMINATION BOOKLET UNTIL THE SIGNAL IS GIVEN.

Part I

Answer all 28 questions in this part. Each correct answer will receive 2 credits. No partial credit will be allowed. For each statement or question, choose the word or expression that, of those given, best completes the statement or answers the question. Record your answers on your separate answer sheet. [56]

Use this space for computations.

1 A rectangular prism is shown in the diagram below.

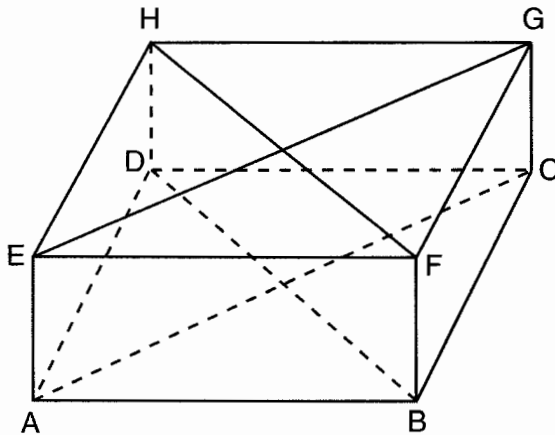

Which pair of line segments would always be both congruent and parallel?

- (1) \overline{AC} and \overline{FB}
- (2) \overline{FB} and \overline{DB}
- (3) \overline{HF} and \overline{AC}
- (4) \overline{DB} and \overline{HF}

2 In parallelogram $QRST$, diagonal \overline{QS} is drawn. Which statement must always be true?

- (1) $\triangle QRS$ is an isosceles triangle.
- (2) $\triangle STQ$ is an acute triangle.
- (3) $\triangle STQ \cong \triangle QRS$
- (4) $\overline{QS} \cong \overline{QT}$

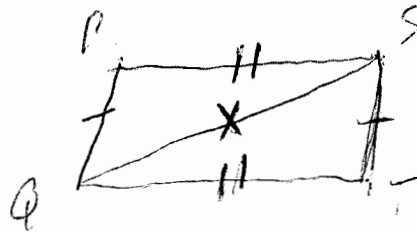

3 In the diagram below of circle O , diameter \overline{AB} and chord \overline{CD} intersect at E .

Use this space for computations.

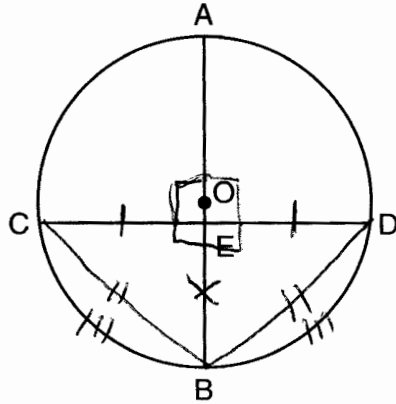

SAS

If $\overline{AB} \perp \overline{CD}$, which statement is always true?

- (1) $\widehat{AC} \cong \widehat{BD}$ (3) $\widehat{AD} \cong \widehat{BC}$
 (2) $\widehat{BD} \cong \widehat{DA}$ (4) $\widehat{CB} \cong \widehat{BD}$

4 What is an equation of the line that passes through $(-9,12)$ and is perpendicular to the line whose equation is $y = \frac{1}{3}x + 6$?

- (1) $y = \frac{1}{3}x + 15$ (3) $y = \frac{1}{3}x - 13$
 (2) $y = -3x - 15$ (4) $y = -3x + 27$

$m = \frac{1}{3}$ $m_{\perp} = -3$
 $y = mx + b$
 $12 = -3(-9) + b$
 $12 = 27 + b$
 $-15 = b$

Use this space for computations.

5 In the diagram below, under which transformation is $\triangle X'Y'Z'$ the image of $\triangle XYZ$?

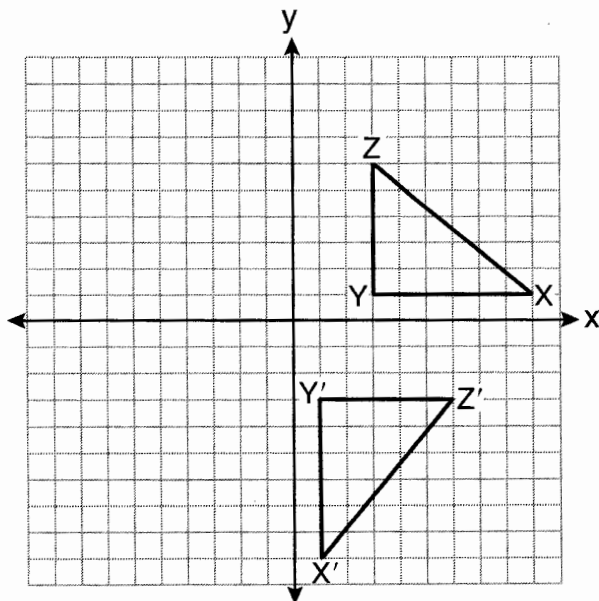

- (1) dilation
- (2) reflection
- (3) rotation
- (4) translation

6 What is the solution of the system of equations $y - x = 5$ and $y = x^2 + 5$?

$y = x + 5$

- (1) (0,5) and (1,6)
- (2) (0,5) and (-1,6)
- (3) (2,9) and (-1,4)
- (4) (-2,9) and (-1,4)

$x^2 + 5 = x + 5$
 $x^2 - x = 0$
 $x(x - 1) = 0$
 $x = 0, 1$
 $y = 0 + 5 = 5$ $y = 1 + 5 = 6$
 (0, 5) (1, 6)

Use this space for computations.

7 In the diagram below, parallelogram $ABCD$ has vertices $A(1,3)$, $B(5,7)$, $C(10,7)$, and $D(6,3)$. Diagonals \overline{AC} and \overline{BD} intersect at E .

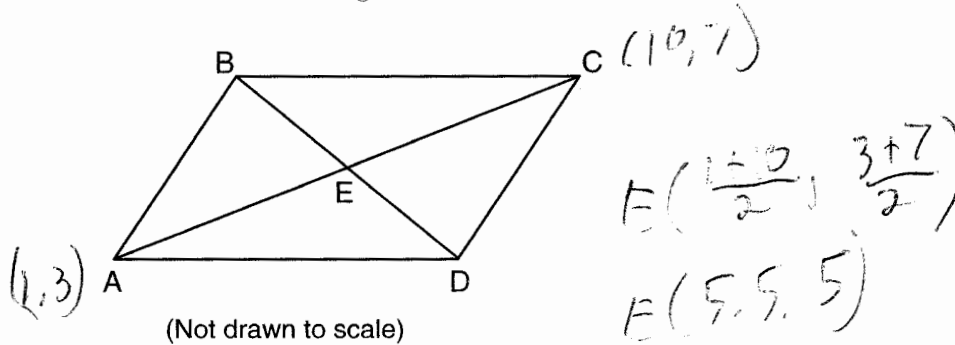

What are the coordinates of point E ?

- (1) $(0.5, 2)$ (3) $(5.5, 5)$
 (2) $(4.5, 2)$ (4) $(7.5, 7)$

8 Right triangle ABC is shown in the graph below.

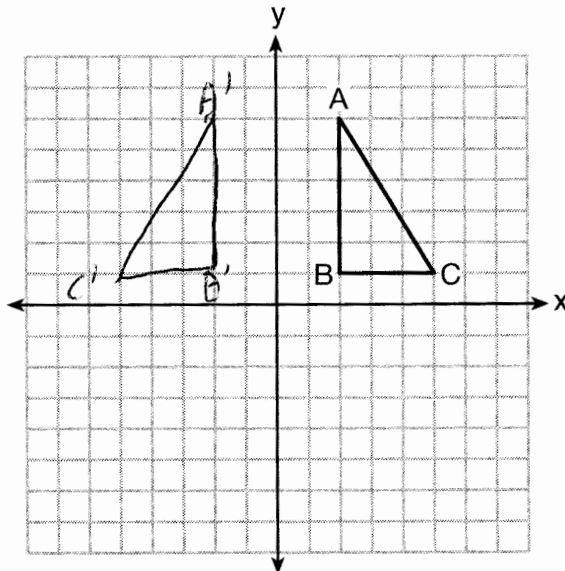

After a reflection over the y -axis, the image of $\triangle ABC$ is $\triangle A'B'C'$. Which statement is *not* true?

- (1) $\overline{BC} \cong \overline{B'C'}$ (3) $AB = A'B'$
 (2) $\overline{A'B'} \perp \overline{B'C'}$ (4) $\overline{AC} \parallel \overline{A'C'}$

Use this space for
computations.

9 What is an equation of circle O shown in the graph below?

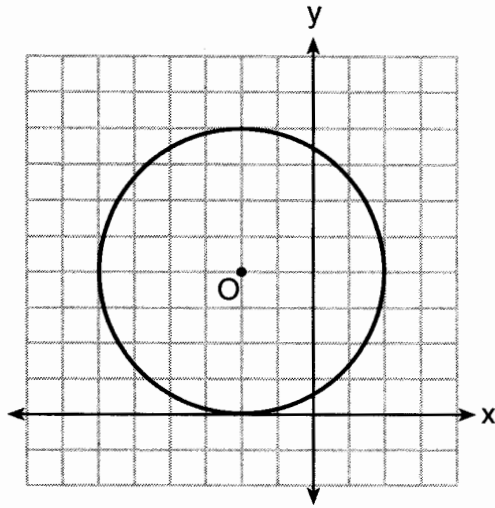

- (1) $(x - 2)^2 + (y + 4)^2 = 4$
- (2) $(x - 2)^2 + (y + 4)^2 = 16$
- (3) $(x + 2)^2 + (y - 4)^2 = 4$
- (4) $(x + 2)^2 + (y - 4)^2 = 16$

10 In the diagram below of right triangle ABC , an altitude is drawn to the hypotenuse \overline{AB} .

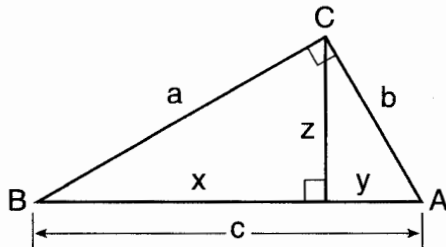

Which proportion would always represent a correct relationship of the segments?

- (1) $\frac{c}{z} = \frac{z}{y}$
- (2) $\frac{c}{a} = \frac{a}{y}$
- (3) $\frac{x}{z} = \frac{z}{y}$
- (4) $\frac{y}{b} = \frac{b}{x}$

Use this space for computations.

11 Quadrilateral $ABCD$ is graphed on the set of axes below.

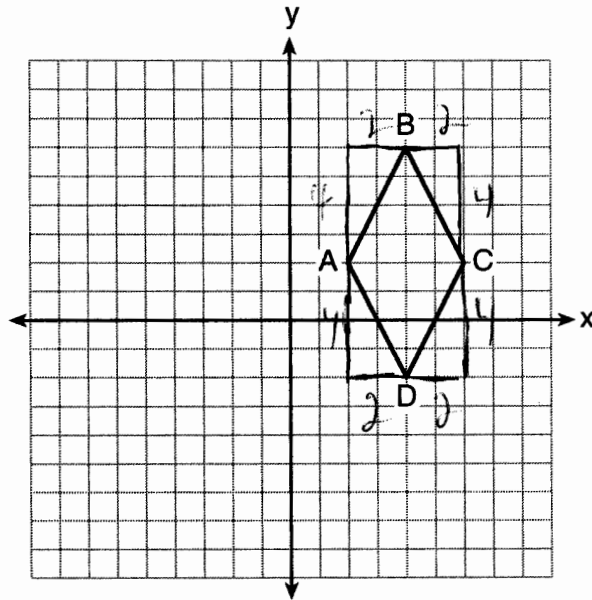

Which quadrilateral best classifies $ABCD$?

- (1) trapezoid *2 pairs of parallel sides*
 (2) rectangle *No right angles*
 (3) rhombus *4 equal sides*
 (4) square *No right angles*

12 Circle O is represented by the equation $(x + 3)^2 + (y - 5)^2 = 48$. The coordinates of the center and the length of the radius of circle O are

- (1) $(-3, 5)$ and $4\sqrt{3}$
 (2) $(-3, 5)$ and 24
 (3) $(3, -5)$ and $4\sqrt{3}$
 (4) $(3, -5)$ and 24

13 In the diagram below of circle O , chord \overline{AB} is parallel to chord \overline{CD} .

Use this space for computations.

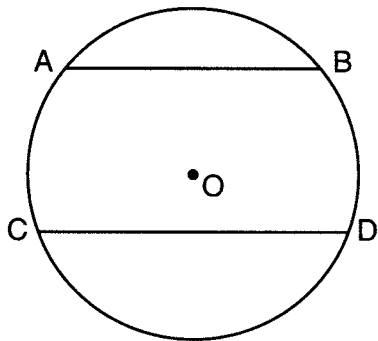

A correct justification for $m\widehat{AC} = m\widehat{BD}$ in circle O is

- (1) parallel chords intercept congruent arcs
- (2) congruent chords intercept congruent arcs
- (3) if two chords are parallel, then they are congruent
- (4) if two chords are equidistant from the center, then the arcs they intercept are congruent

14 What is the slope of a line perpendicular to the line whose equation is $3x - 7y + 14 = 0$?

(1) $\frac{3}{7}$

(3) 3

$$M = \frac{-A}{B} = \frac{-3}{-7} = \frac{3}{7}$$

(2) $-\frac{7}{3}$

(4) $-\frac{1}{3}$

$$M_{\perp} = -\frac{7}{3}$$

15 Line segment AB has endpoint A located at the origin. Line segment AB is longest when the coordinates of B are

(1) $(3,7) \sqrt{9+49} = \sqrt{58}$

(3) $(-6,4) \sqrt{36+16} = \sqrt{52}$

(2) $(2,-8) \sqrt{4+64} = \sqrt{68}$

(4) $(-5,-5) \sqrt{25+25} = \sqrt{50}$

Use this space for computations.

16 In $\triangle FGH$, $m\angle F = m\angle H$, $GF = x + 40$, $HF = 3x - 20$, and $GH = 2x + 20$. The length of \overline{GH} is

- (1) 20
- (2) 40

- (3) 60
- (4) 80

$$\begin{aligned}x + 40 &= 2x + 20 \\ 20 &= x \\ GH &= 2(20) + 20 = 60\end{aligned}$$

17 In the diagram below of quadrilateral $ABCD$, diagonals \overline{AEC} and \overline{BED} are perpendicular at E .

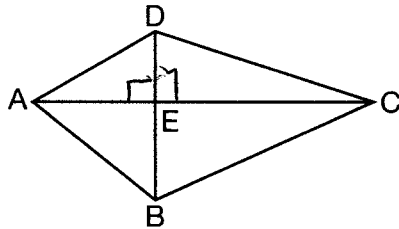

Which statement is always true based on the given information?

- (1) $\overline{DE} \cong \overline{EB}$
- (2) $\overline{AD} \cong \overline{AB}$

- (3) $\angle DAC \cong \angle BAC$
- (4) $\angle AED \cong \angle CED$

18 Which set of numbers could represent the lengths of the sides of a right triangle?

- (1) {2, 3, 4}
- (2) {5, 9, 13}

- (3) {7, 7, 12}
- (4) {8, 15, 17}

$$8^2 + 15^2 = 17^2$$

19 In quadrilateral $ABCD$, the diagonals bisect its angles. If the diagonals are *not* congruent, quadrilateral $ABCD$ must be a

- (1) square
- (2) rectangle

- (3) rhombus
- (4) trapezoid

Use this space for
computations.

20 Line m and point P are shown in the graph below.

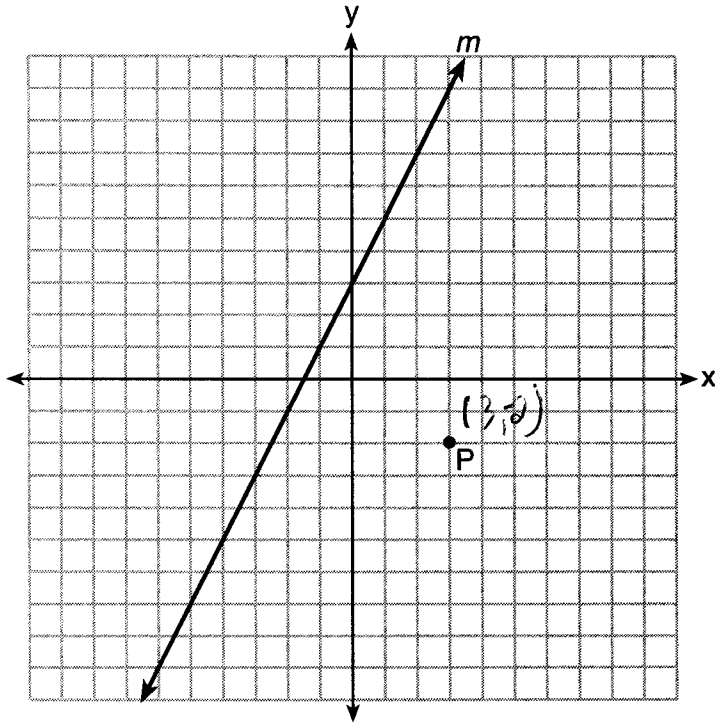

Which equation represents the line passing through P and parallel to line m ?

(1) $y - 3 = 2(x + 2)$

(3) $y - 3 = -\frac{1}{2}(x + 2)$

(2) $y + 2 = 2(x - 3)$

(4) $y + 2 = -\frac{1}{2}(x - 3)$

21 Which compound statement is true?

(1) A square has four sides or a hexagon has eight sides.

(2) A square has four sides and a hexagon has eight sides.

(3) If a square has four sides, then a hexagon has eight sides.

(4) A square has four sides if and only if a hexagon has eight sides.

Use this space for computations.

22 In $\triangle CAT$, $m\angle C = 65$, $m\angle A = 40$, and B is a point on side \overline{CA} , such that $\overline{TB} \perp \overline{CA}$. Which line segment is shortest?

- (1) \overline{CT} (3) \overline{TB}
 (2) \overline{BC} (4) \overline{AT}

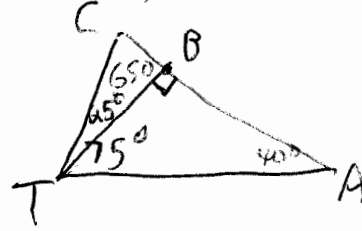

23 In the diagram of $\triangle ABC$ below, $\overline{DE} \parallel \overline{BC}$, $AD = 3$, $DB = 2$, and $DE = 6$.

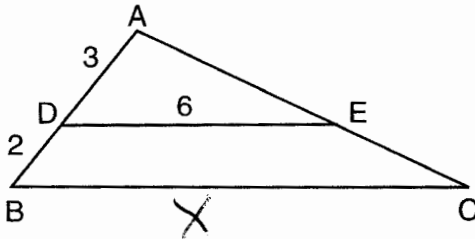

$$\frac{3}{6} = \frac{5}{x}$$

$$3x = 30$$

$$x = 10$$

What is the length of \overline{BC} ?

- (1) 12 (3) 8
 (2) 10 (4) 4

24 In $\triangle ABC$, an exterior angle at C measures 50° . If $m\angle A > 30$, which inequality must be true?

- (1) $m\angle B < 20$ (3) $m\angle BCA < 130$
 (2) $m\angle B > 20$ (4) $m\angle BCA > 130$

$$m\angle C = 130$$

Use this space for computations.

25 Which graph represents the graph of the equation $(x - 1)^2 + y^2 = 4$?

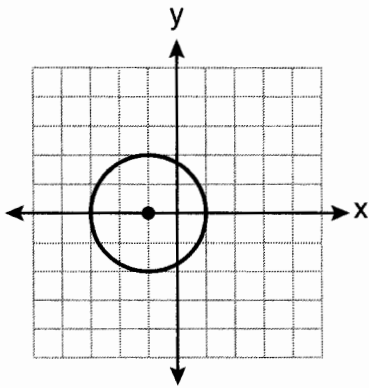

(1)

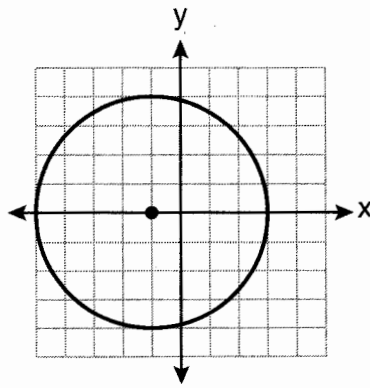

(3)

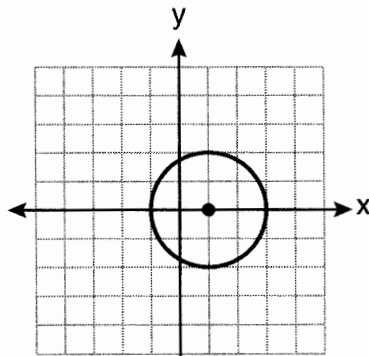

(2)

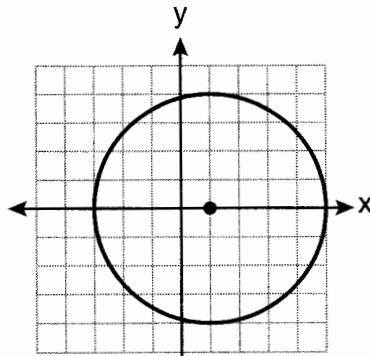

(4)

26 The equations of lines k , p , and m are given below: $m = -\frac{A}{B}$

$k: x + 2y = 6$ $-\frac{1}{2}$
 $p: 6x + 3y = 12$ $-\frac{6}{3} = -2$
 $m: -x + 2y = 10$ $\frac{1}{2}$

Which statement is true?

- (1) $p \perp m$
- (2) $m \perp k$

- (3) $k \parallel p$
- (4) $m \parallel k$

- 27 Peach Street and Cherry Street are parallel. Apple Street intersects them, as shown in the diagram below.

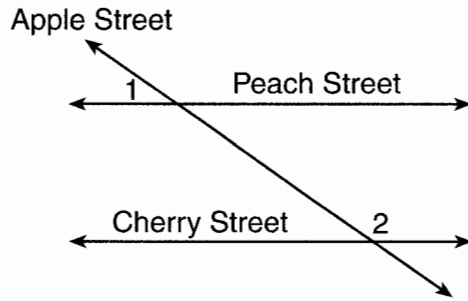

Use this space for computations.

$$2x + 36 + 7x - 9 = 180$$

$$9x + 27 = 180$$

$$9x = 153$$

$$x = 17$$

$$m\angle 1 = 2(17) + 36 = 70$$

If $m\angle 1 = 2x + 36$ and $m\angle 2 = 7x - 9$, what is $m\angle 1$?

- (1) 9
 (2) 17
 (3) 54
 (4) 70
- 28 A regular pyramid has a height of 12 centimeters and a square base. If the volume of the pyramid is 256 cubic centimeters, how many centimeters are in the length of one side of its base?

(1) 8

(3) 32

(2) 16

(4) 64

$$V = \frac{1}{3} Bh$$

$$256 = \frac{1}{3} B \cdot 12$$

$$64 = B$$

$$8 = s$$

Part II

Answer all 6 questions in this part. Each correct answer will receive 2 credits. Clearly indicate the necessary steps, including appropriate formula substitutions, diagrams, graphs, charts, etc. For all questions in this part, a correct numerical answer with no work shown will receive only 1 credit. All answers should be written in pen, except for graphs and drawings, which should be done in pencil. [12]

29 Triangle ABC has coordinates $A(-2,1)$, $B(3,1)$, and $C(0,-3)$. On the set of axes below, graph and label $\triangle A'B'C'$, the image of $\triangle ABC$ after a dilation of 2.

$A'(-4,2)$ $B'(6,2)$ $C'(0,-6)$

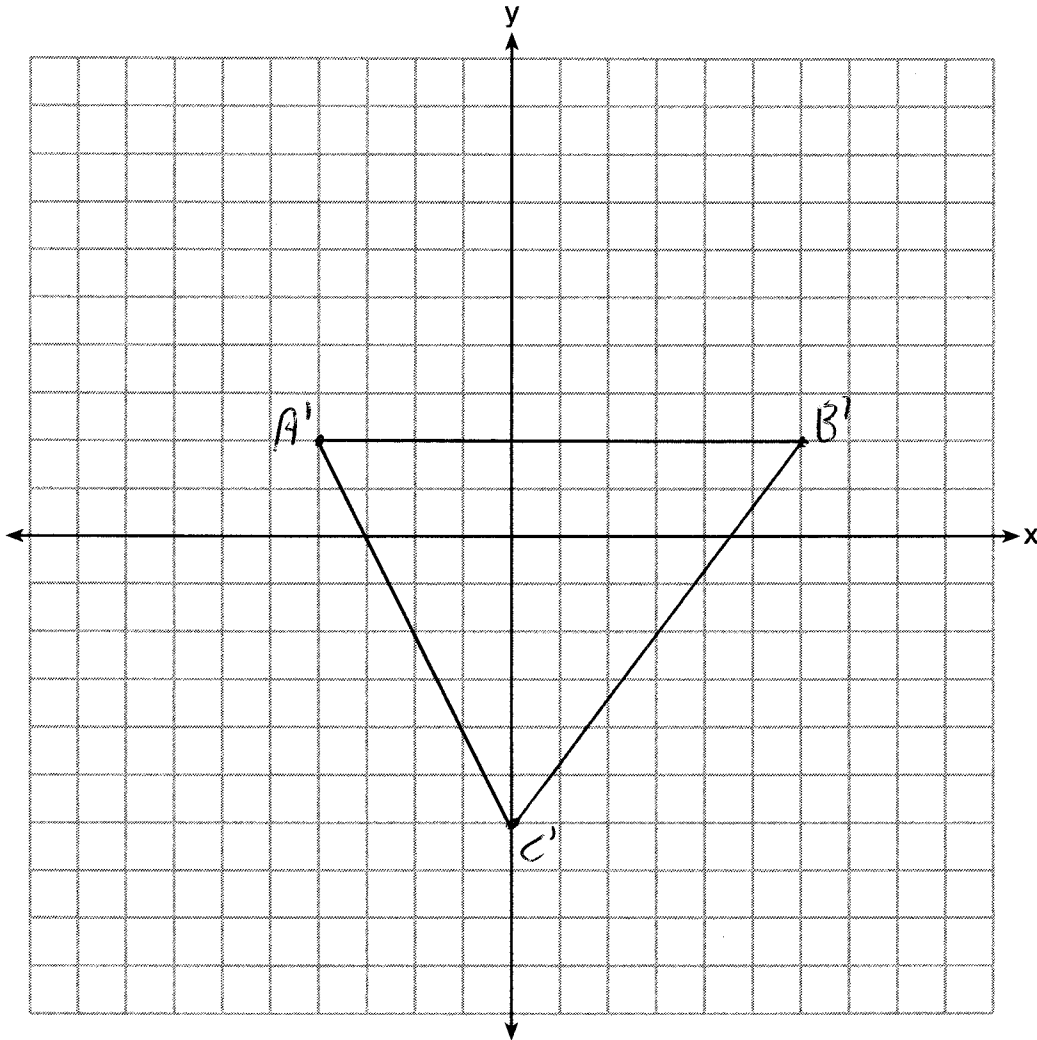

30 In the diagram below of $\triangle ABC$, \overline{DE} and \overline{DF} are midsegments.

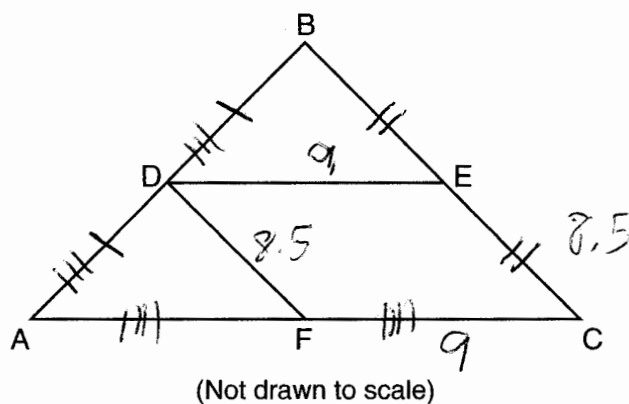

If $DE = 9$, and $BC = 17$, determine and state the perimeter of quadrilateral $FDEC$.

$$8.5 + 9 + 8.5 + 9 = 35$$

31 The image of $\triangle ABC$ under a translation is $\triangle A'B'C'$. Under this translation, $B(3, -2)$ maps onto $B'(1, -1)$. Using this translation, the coordinates of image A' are $(-2, 2)$. Determine and state the coordinates of point A .

$$T_{-2, 1}$$
$$A(0, 1)$$

32 As shown in the diagram below, quadrilateral $DEFG$ is inscribed in a circle and $m\angle D = 86$.

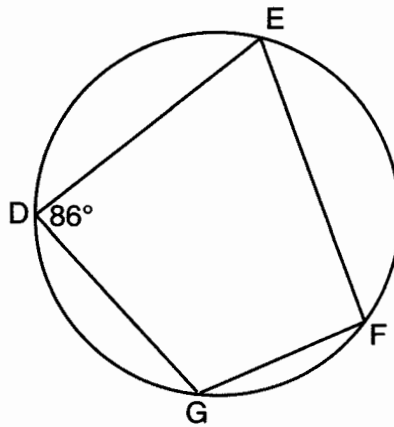

Determine and state $m\widehat{GFE}$.

$$86 \cdot 2 = 172$$

Determine and state $m\angle F$.

$$180 - 86 = 94$$

33 In the diagram below, \overline{QM} is a median of triangle PQR and point C is the centroid of triangle PQR .

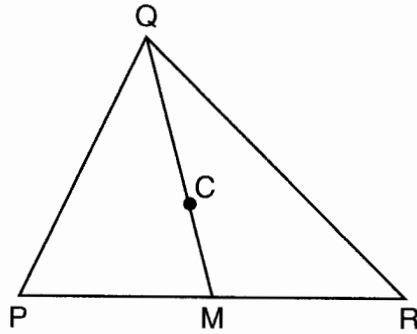

If $QC = 5x$ and $CM = x + 12$, determine and state the length of \overline{QM} .

$$5x = 2(x + 12)$$

$$5x = 2x + 24$$

$$3x = 24$$

$$x = 8$$

$$QM = 5(8) + (8) + 12 = 60$$

34 The sum of the interior angles of a regular polygon is 540° . Determine and state the number of degrees in one interior angle of the polygon.

$$180(n-2) = 540$$

$$n-2 = 3$$

$$n = 5$$

$$\frac{540}{5} = 108$$

Part III

Answer all 3 questions in this part. Each correct answer will receive 4 credits. Clearly indicate the necessary steps, including appropriate formula substitutions, diagrams, graphs, charts, etc. For all questions in this part, a correct numerical answer with no work shown will receive only 1 credit. All answers should be written in pen, except for graphs and drawings, which should be done in pencil. [12]

35 Given: \overline{MT} and \overline{HA} intersect at B , $\overline{MA} \parallel \overline{HT}$, and \overline{MT} bisects \overline{HA}

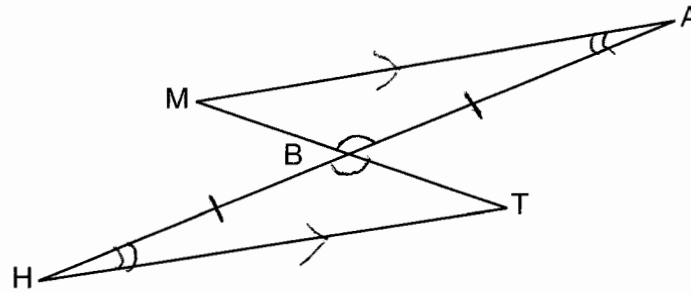

Prove: $\overline{MA} \cong \overline{HT}$

STATEMENT	REASON
1) \overline{MT} & \overline{HA} intersect at B ,	1) Given
$\overline{MA} \parallel \overline{HT}$, & \overline{MT} bisects \overline{HA}	2) Vertical Angles are congruent
2) $\angle MBA \cong \angle T BH$	3) Alternate interior angles formed by parallel lines & a transversal are congruent
3) $\angle H \cong \angle A$	4) The bisection of a line segments creates two congruent segments
4) $\overline{BH} \cong \overline{BA}$	5) ASA
5) $\triangle MAB \cong \triangle THB$	6) CPCTC
6) $\overline{MA} \cong \overline{HT}$	

- 36 A right circular cone has an altitude of 10 ft and the diameter of the base is 6 ft as shown in the diagram below. Determine and state the lateral area of the cone, to the *nearest tenth of a square foot*.

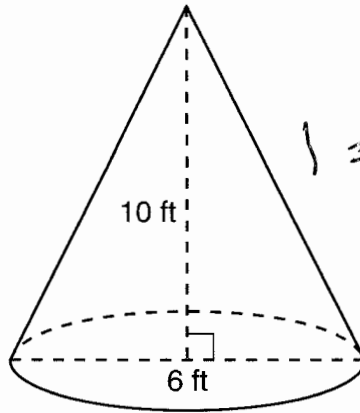

$$l = \sqrt{10^2 + 3^2} = \sqrt{109}$$

$$\begin{aligned} L &= \pi r l \\ &= \pi(3)(\sqrt{109}) \\ &\approx 98.4 \end{aligned}$$

37 Use a compass and straightedge to divide line segment AB below into four congruent parts.
[Leave all construction marks.]

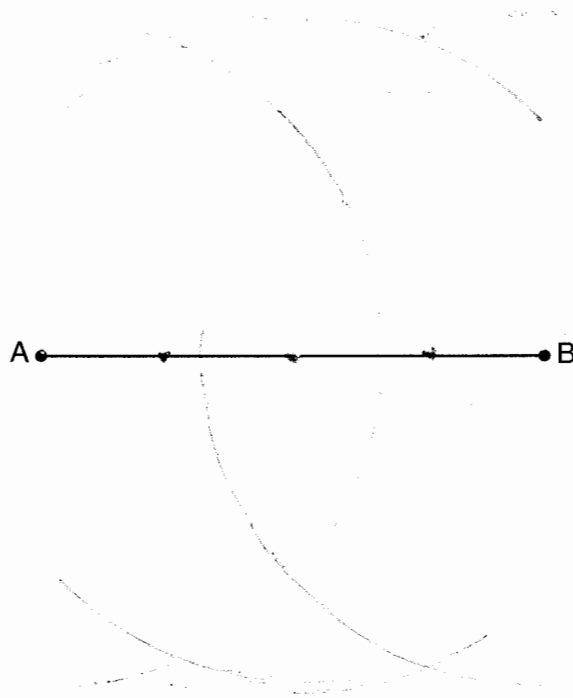

Part IV

Answer the question in this part. A correct answer will receive 6 credits. Clearly indicate the necessary steps, including appropriate formula substitutions, diagrams, graphs, charts, etc. A correct numerical answer with no work shown will receive only 1 credit. The answer should be written in pen, except for graphs and drawings, which should be done in pencil.

38 On the set of axes below, graph the locus of points 5 units from the point $(3, -2)$.

Write an equation that represents this locus.

$$(x-3)^2 + (y+2)^2 = 25$$

On the same set of axes, graph the locus of points equidistant from the points $(0, -6)$ and $(2, -4)$.

Write an equation that represents this locus.

$$y = -x - 4$$

$$m = \frac{-6 - (-4)}{0 - 2} = \frac{-2}{-2} = 1$$

$$m_{\perp} = -1$$

State the coordinates of all points that satisfy both conditions.

$$M\left(\frac{0+2}{2}, \frac{-6+(-4)}{2}\right) = M(1, -5)$$

$$-5 = 1(1) + b$$

$$-4 = b$$

