

The University of the State of New York
REGENTS HIGH SCHOOL EXAMINATION

GEOMETRY

Tuesday, June 16, 2009—9:15 a.m. to 12:15 p.m., only

Student Name: Steve Sibol

School Name: jmap.org

Print your name and the name of your school on the lines above.

This examination has four parts, with a total of 38 questions. You must answer all questions in this examination. Record your answers to the Part I multiple-choice questions, using a No. 2 pencil, on the separate answer sheet provided to you. Write your answers to the questions in Parts II, III, and IV directly in this test booklet. All work for Parts II, III, and IV should be written in pen, except graphs and drawings, which should be done in pencil. Clearly indicate the necessary steps, including appropriate formula substitutions, diagrams, graphs, charts, etc.

The formulas that you may need to answer some questions in this examination are found at the end of the examination. This sheet is perforated so you may remove it from this booklet.

Scrap paper is not permitted for any part of this examination, but you may use the blank spaces in this booklet as scrap paper. A perforated sheet of scrap graph paper is provided at the end of this booklet for any question for which graphing may be helpful but is not required. You may remove this sheet from this booklet. Any work done on this sheet of scrap graph paper will *not* be scored.

When you have completed the examination, you must sign the statement printed at the end of the answer sheet, indicating that you had no unlawful knowledge of the questions or answers prior to the examination and that you have neither given nor received assistance in answering any of the questions during the examination. Your answer sheet cannot be accepted if you fail to sign this declaration.

Notice . . .

A graphing calculator, a straightedge (ruler), and a compass must be available for you to use while taking this examination.

The use of any communications device is strictly prohibited when taking this examination. If you use any communications device, no matter how briefly, your examination will be invalidated and no score will be calculated for you.

DO NOT OPEN THIS EXAMINATION BOOKLET UNTIL THE SIGNAL IS GIVEN.

Part I

Answer all 28 questions in this part. Each correct answer will receive 2 credits. No partial credit will be allowed. For each question, record your answer, using a No. 2 pencil, on the separate answer sheet provided to you. [56]

Use this space for computations.

- 1 Juliann plans on drawing $\triangle ABC$, where the measure of $\angle A$ can range from 50° to 60° and the measure of $\angle B$ can range from 90° to 100° . Given these conditions, what is the correct range of measures possible for $\angle C$?

- (1) 20° to 40°
 (2) 30° to 50°

- (3) 80° to 90°
 (4) 120° to 130°

$$180 - (50 + 90) = 40$$

$$180 - (60 + 100) = 20$$

- 2 In the diagram of $\triangle ABC$ and $\triangle DEF$ below, $\overline{AB} \cong \overline{DE}$, $\angle A \cong \angle D$, and $\angle B \cong \angle E$.

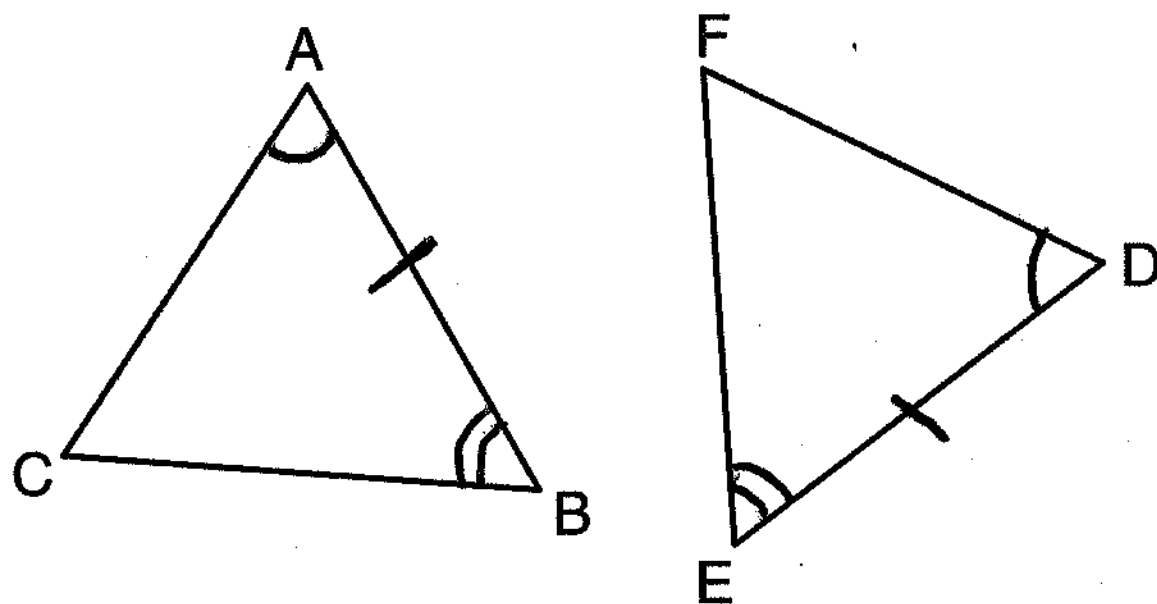

Which method can be used to prove $\triangle ABC \cong \triangle DEF$?

- (1) SSS
 (2) SAS
 (3) ASA
 (4) HL

Use this space for
computations.

- 3 In the diagram below, under which transformation will $\triangle A'B'C'$ be the image of $\triangle ABC$?

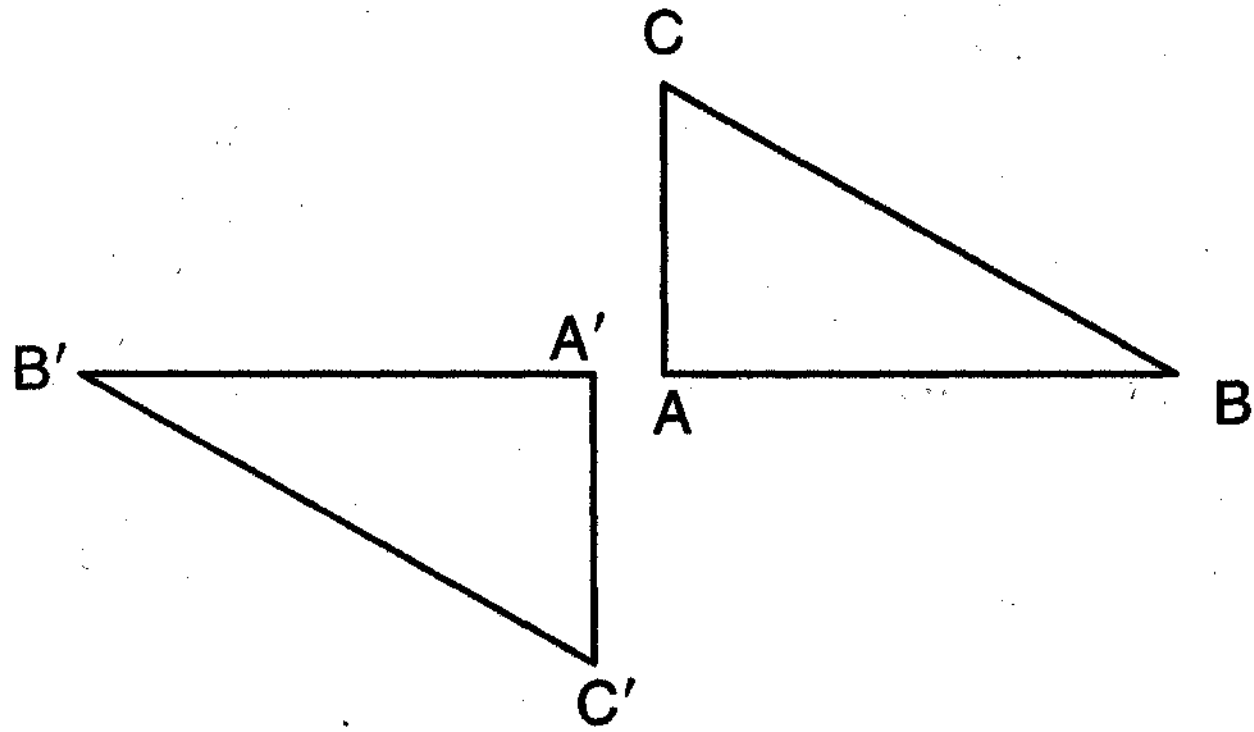

- (1) rotation
(2) dilation
(3) translation
(4) glide reflection
- 4 The lateral faces of a regular pyramid are composed of
(1) squares
(2) rectangles
(3) congruent right triangles
(4) congruent isosceles triangles

- 5 Point A is located at $(4, -7)$. The point is reflected in the x -axis. Its image is located at
(1) $(-4, 7)$
(2) $(-4, -7)$
(3) $(4, 7)$
(4) $(7, -4)$

Use this space for computations.

- 8 After a composition of transformations, the coordinates $A(4,2)$, $B(4,6)$, and $C(2,6)$ become $A''(-2,-1)$, $B''(-2,-3)$, and $C''(-1,-3)$, as shown on the set of axes below.

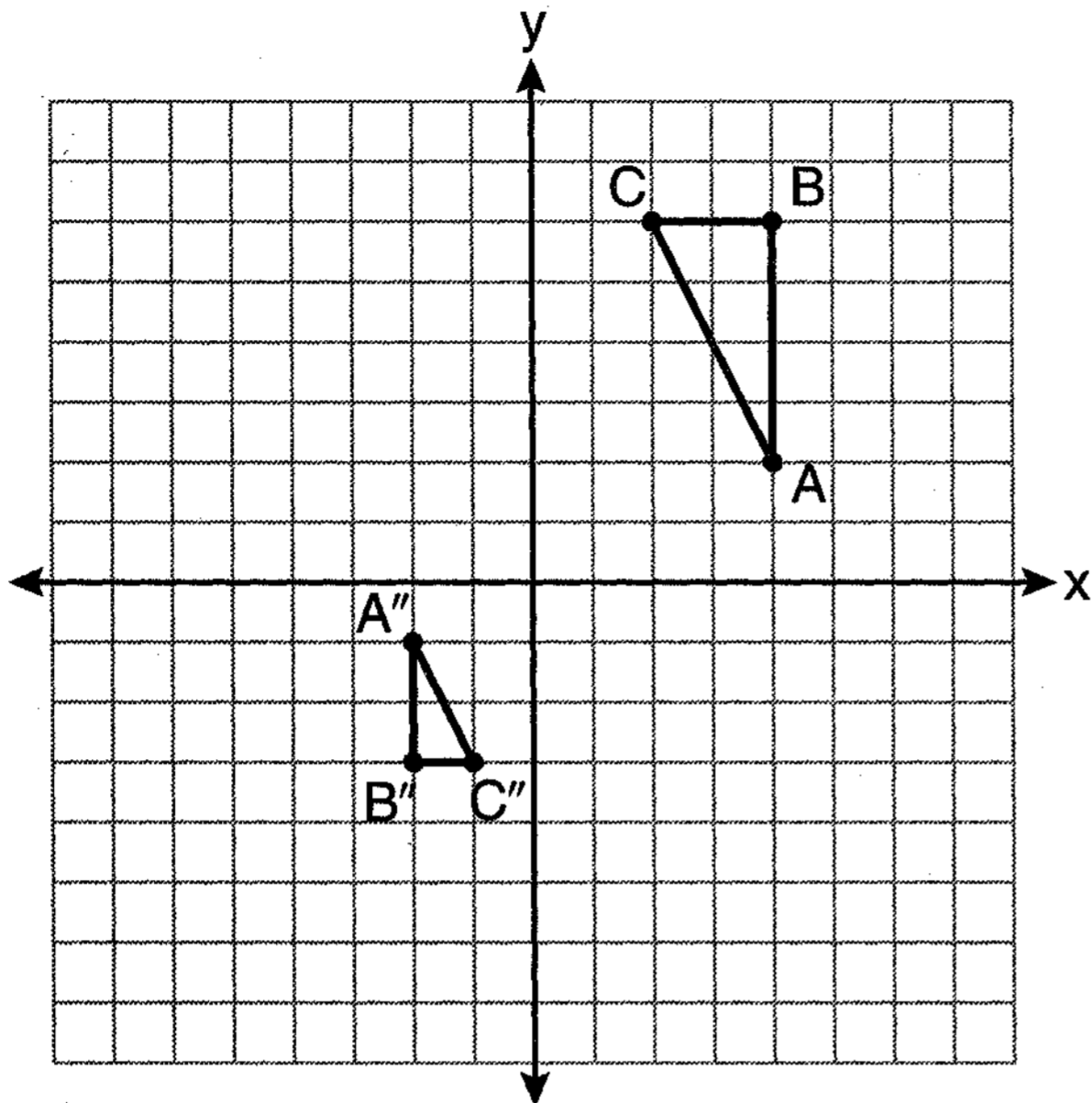

Which composition of transformations was used?

- (1) $R_{180^\circ} \circ D_2$ (3) $D_{\frac{1}{2}} \circ R_{180^\circ}$
 (2) $R_{90^\circ} \circ D_2$ (4) $D_{\frac{1}{2}} \circ R_{90^\circ}$

- 9 In an equilateral triangle, what is the difference between the sum of the exterior angles and the sum of the interior angles?

- (1) 180° (3) 90°
 (2) 120° (4) 60°

interior angles = 180 (60x3)
 exterior angles = 360 (120x3)
 180

Use this space for
computations.

10 What is an equation of a circle with its center at $(-3, 5)$ and a radius of 4?

(1) $(x - 3)^2 + (y + 5)^2 = 16$

(2) $(x + 3)^2 + (y - 5)^2 = 16$

(3) $(x - 3)^2 + (y + 5)^2 = 4$

(4) $(x + 3)^2 + (y - 5)^2 = 4$

11 In $\triangle ABC$, $m\angle A = 95$, $m\angle B = 50$, and $m\angle C = 35$. Which expression correctly relates the lengths of the sides of this triangle?

(1) $AB < BC < CA$

(3) $AC < BC < AB$

(2) $AB < AC < BC$

(4) $BC < AC < AB$

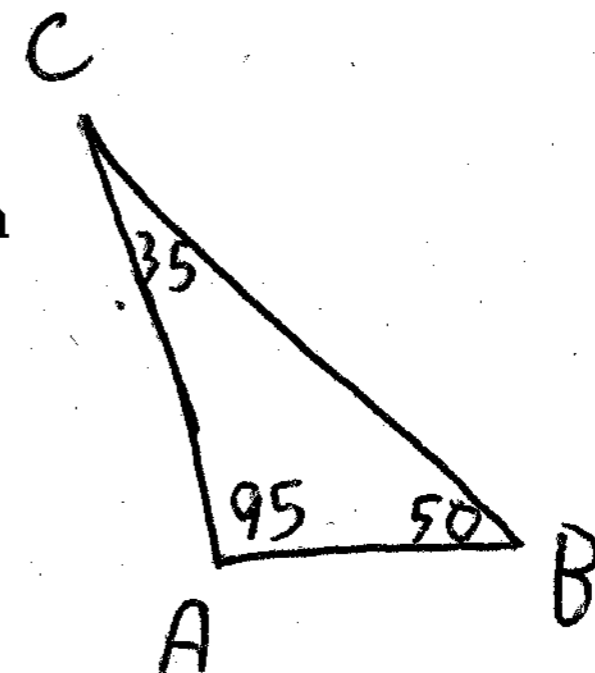

12 In a coordinate plane, how many points are both 5 units from the origin and 2 units from the x -axis?

(1) 1

(3) 3

(2) 2

(4) 4

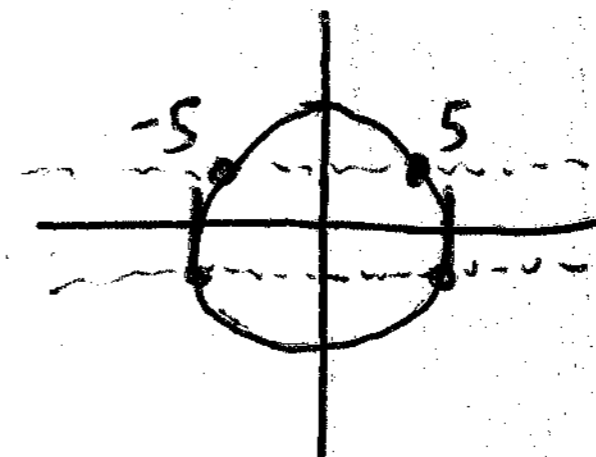

13 What is the contrapositive of the statement, "If I am tall, then I will bump my head"?

(1) If I bump my head, then I am tall.

(2) If I do not bump my head, then I am tall.

(3) If I am tall, then I will not bump my head.

(4) If I do not bump my head, then I am not tall.

Use this space for computations.

- 14 In the diagram of $\triangle ABC$ below, Jose found centroid P by constructing the three medians. He measured \overline{CF} and found it to be 6 inches.

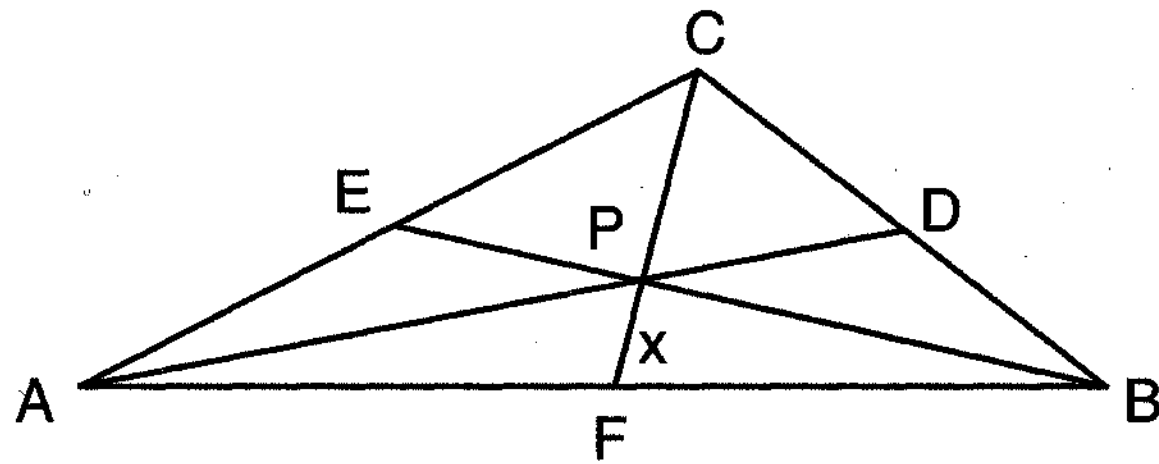

If $PF = x$, which equation can be used to find x ?

- (1) $x + x = 6$ (3) $3x + 2x = 6$
 (2) $2x + x = 6$ (4) $x + \frac{2}{3}x = 6$

The centroid divides each median into segments whose lengths are in the ratio 2:1.
 $1/3 \overline{CF} = x, \overline{CP} = 2x$

- 15 In the diagram below, the length of the legs \overline{AC} and \overline{BC} of right triangle ABC are 6 cm and 8 cm, respectively. Altitude \overline{CD} is drawn to the hypotenuse of $\triangle ABC$.

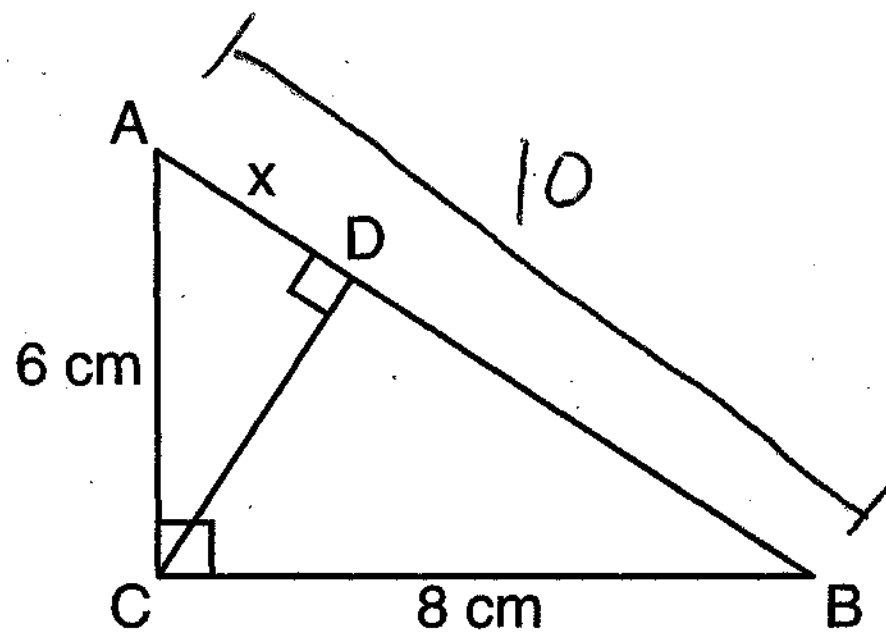

$$\begin{aligned} a^2 + b^2 &= c^2 \\ 6^2 + 8^2 &= c^2 \\ 100 &= c^2 \\ 10 &= c \end{aligned}$$

What is the length of \overline{AD} to the nearest tenth of a centimeter?

- (1) 3.6 (3) 6.4
 (2) 6.0 (4) 4.0

$$\begin{aligned} 10x &= 6^2 \\ \cancel{10x} &= \frac{36}{\cancel{10} \cdot 10} \\ x &= 3.6 \end{aligned}$$

Use this space for computations.

- 16 In the diagram below, tangent \overline{AB} and secant \overline{ACD} are drawn to circle O from an external point A , $AB = 8$, and $AC = 4$.

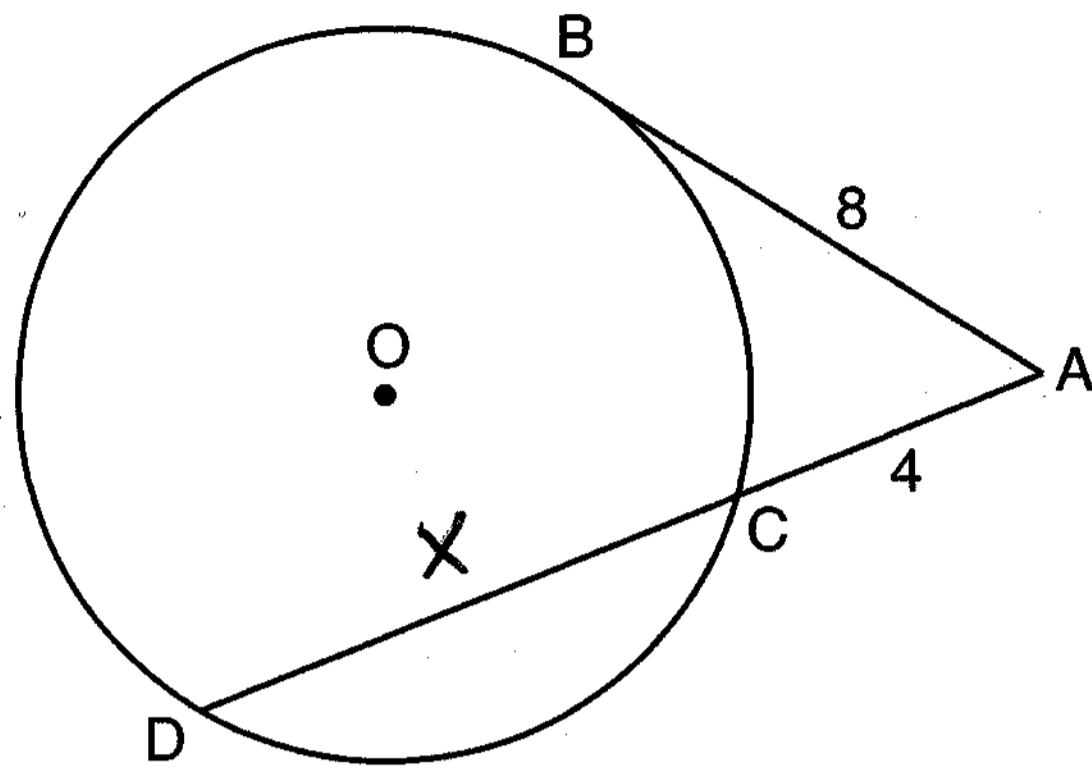

$$\begin{aligned} WE &= WE \\ 8 \cdot 8 &= (x+4)4 \\ 64 &= 4x+16 \\ \frac{48}{4} &= \frac{4x}{4} \\ 12 &= x \end{aligned}$$

What is the length of \overline{CD} ?

- (1) 16
 (2) 13
 (3) 12
 (4) 10

- 17 In the diagram of $\triangle ABC$ and $\triangle EDC$ below, \overline{AE} and \overline{BD} intersect at C , and $\angle CAB \cong \angle CED$.

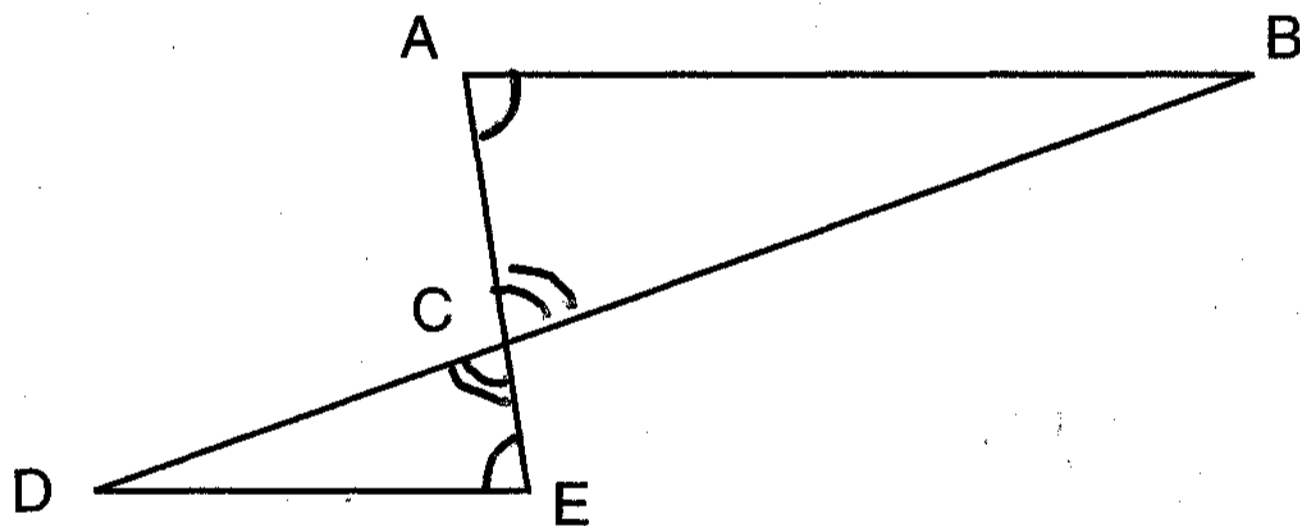

Which method can be used to show that $\triangle ABC$ must be similar to $\triangle EDC$?

- (1) SAS
 (2) AA
 (3) SSS
 (4) HL

Use this space for
computations.

18 Point P is on line m . What is the total number of planes that are perpendicular to line m and pass through point P ?

- (1) 1
(2) 2
(3) 0
(4) infinite

19 Square $LMNO$ is shown in the diagram below.

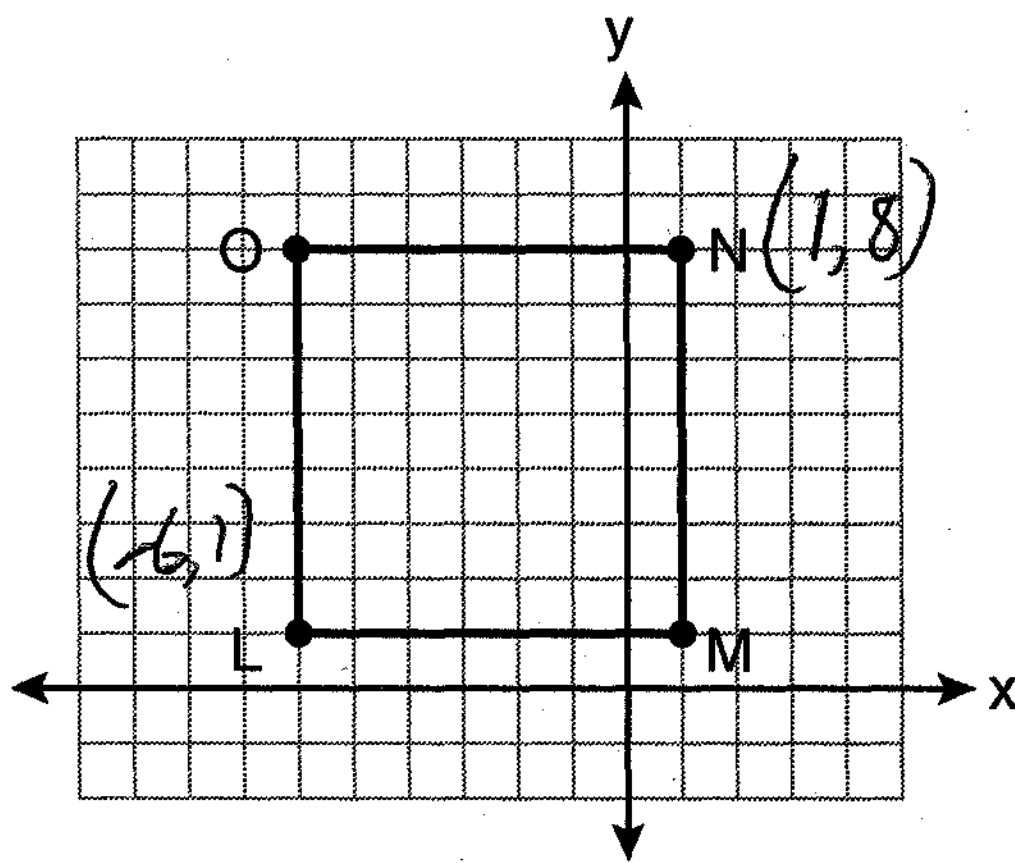

What are the coordinates of the midpoint of diagonal \overline{LN} ?

- (1) $(4\frac{1}{2}, -2\frac{1}{2})$
(2) $(-3\frac{1}{2}, 3\frac{1}{2})$
(3) $(-2\frac{1}{2}, 3\frac{1}{2})$
(4) $(-2\frac{1}{2}, 4\frac{1}{2})$

$$\frac{-6+1}{2} = \frac{-5}{2} = -2\frac{1}{2}$$
$$\frac{1+8}{2} = \frac{9}{2} = 4\frac{1}{2}$$

Use this space for
computations.

20 Which graph represents a circle with the equation

$$(x - 5)^2 + (y + 1)^2 = 9?$$

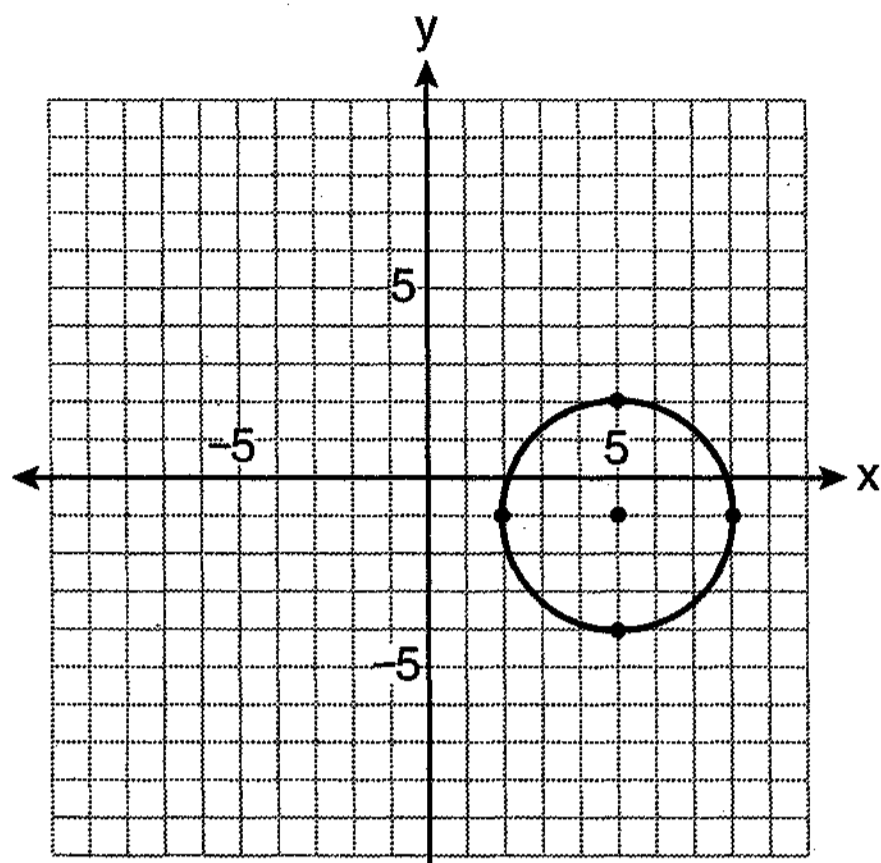

(1)

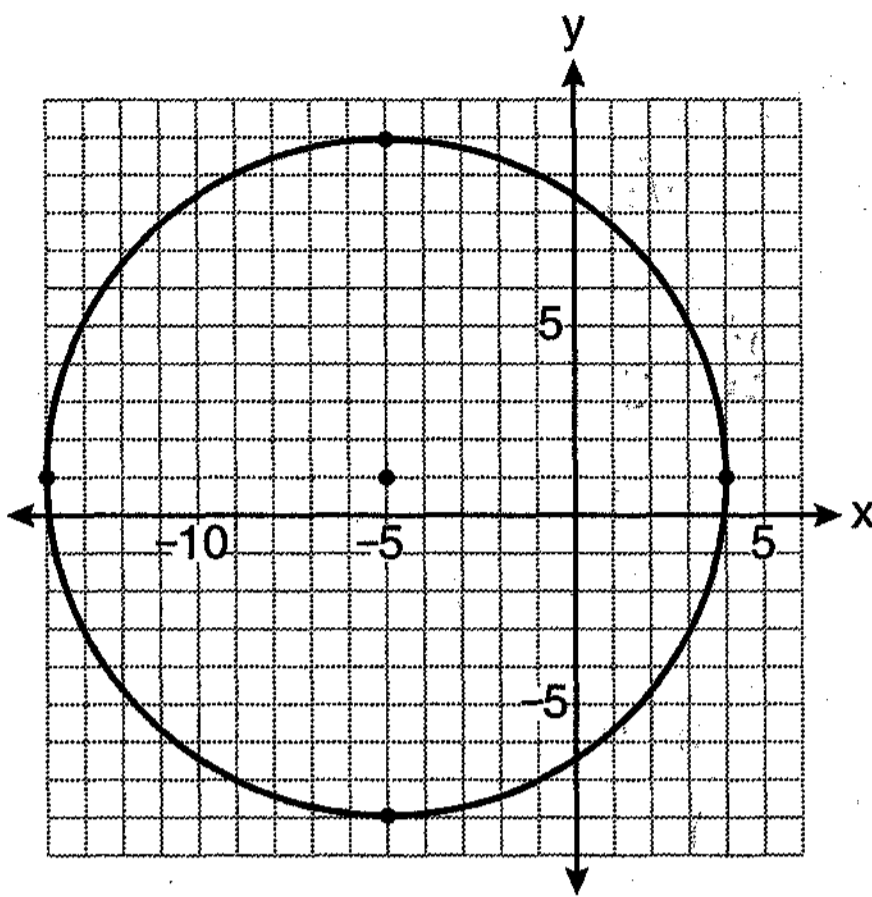

(3)

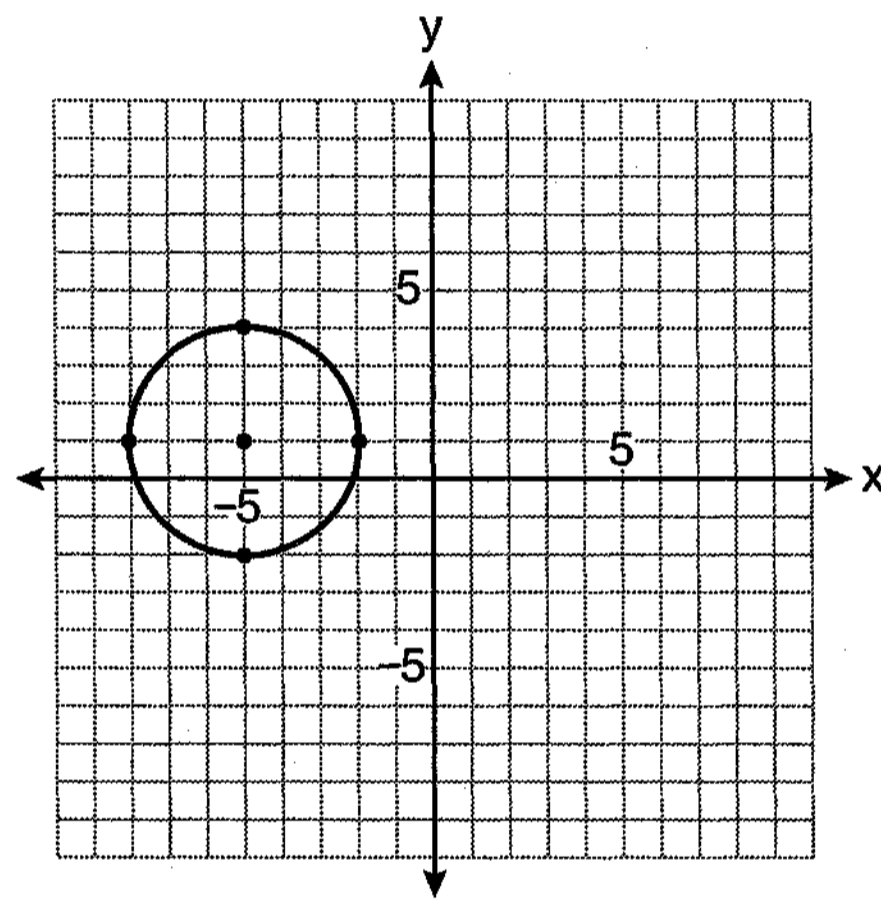

(2)

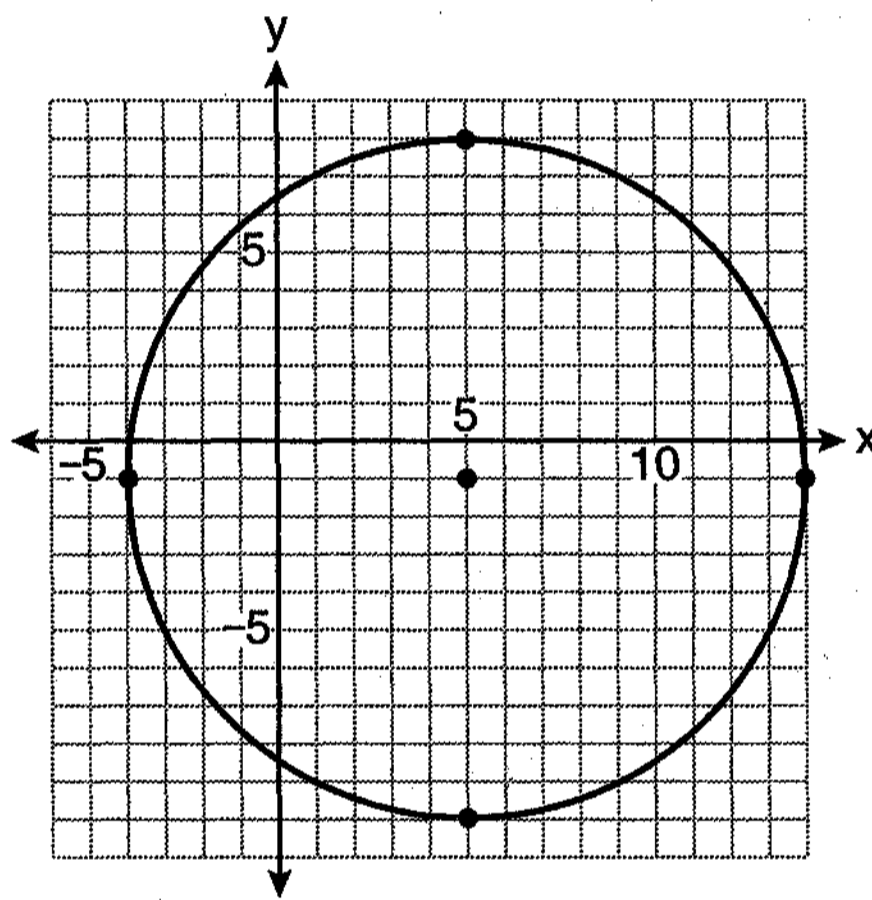

(4)

Use this space for
computations.

- 21 In the diagram below, a right circular cone has a diameter of 8 inches and a height of 12 inches.

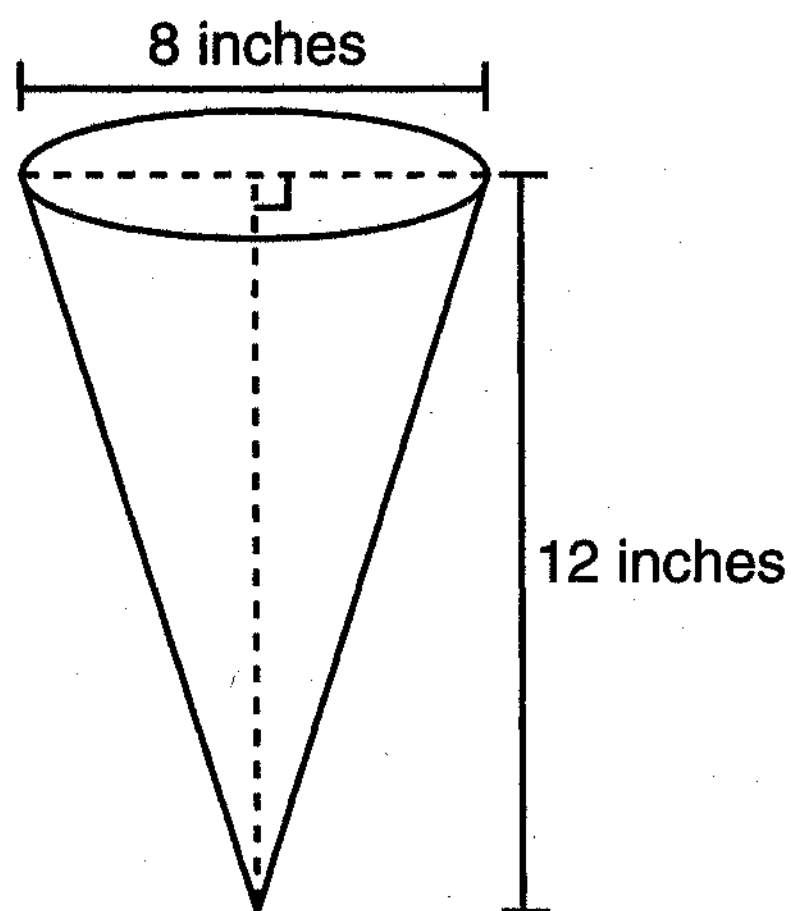

$$V = \frac{1}{3} B h$$

$$V = \frac{1}{3} \pi r^2 h$$

$$V = \frac{1}{3} \pi \cdot 4^2 \cdot 12$$

$$V \approx 201$$

What is the volume of the cone to the *nearest cubic inch*?

- (1) 201
(2) 481
(3) 603
(4) 804
- 22 A circle is represented by the equation $x^2 + (y + 3)^2 = 13$. What are the coordinates of the center of the circle and the length of the radius?
- (1) (0,3) and 13
(2) (0,3) and $\sqrt{13}$
(3) (0,-3) and 13
(4) (0,-3) and $\sqrt{13}$

Use this space for computations.

23 Given the system of equations:

$$y = x^2 - 4x$$

$$x = 4$$

The number of points of intersection is

(1) 1

(2) 2

(3) 3

(4) 0

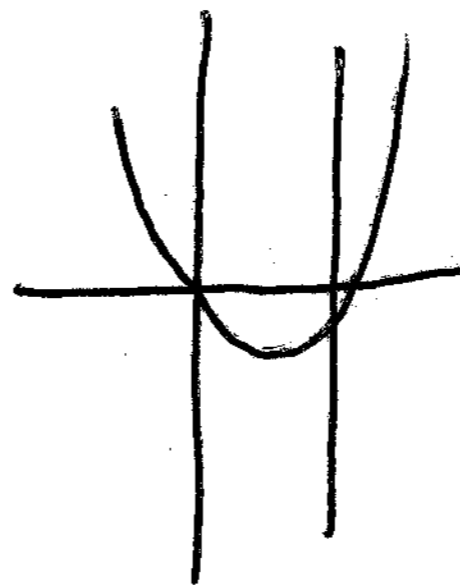

24 Side \overline{PQ} of $\triangle PQR$ is extended through Q to point T . Which statement is *not* always true?

(1) $m\angle RQT > m\angle R$

(2) $m\angle RQT > m\angle P$

(3) $m\angle RQT = m\angle P + m\angle R$

(4) $m\angle RQT > m\angle PQR$

25 Which illustration shows the correct construction of an angle bisector?

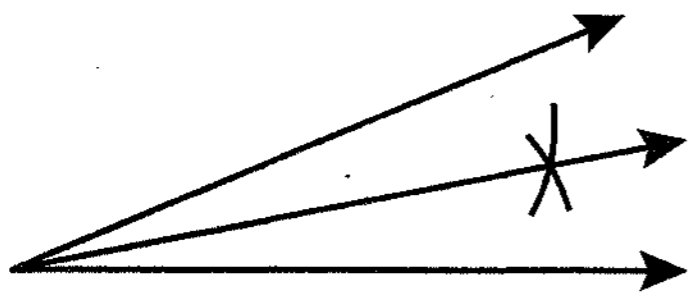

(1)

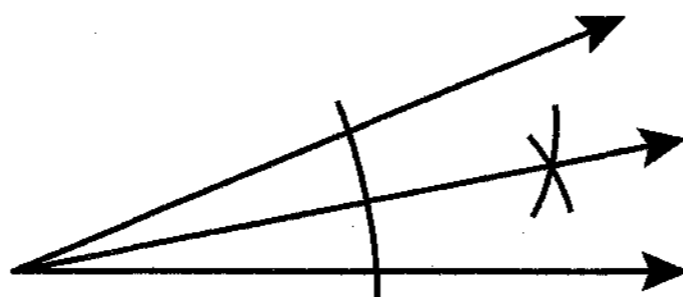

(3)

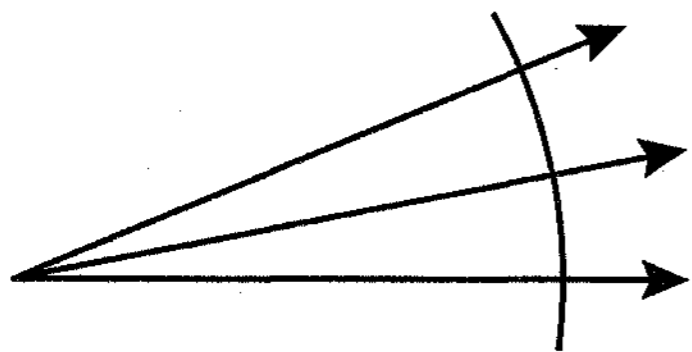

(2)

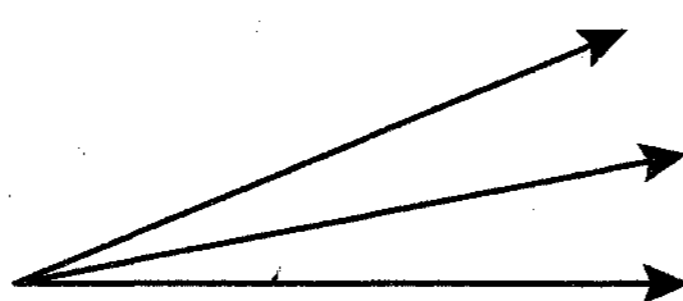

(4)

Use this space for computations.

26 Which equation represents a line perpendicular to the line whose equation is $2x + 3y = 12$?

$m = -\frac{A}{B} = -\frac{2}{3}$ $m_{\perp} = \frac{3}{2}$

(1) $6y = -4x + 12$

(3) $2y = -3x + 6$

(2) $\frac{2y}{2} = \frac{3x}{2} + \frac{6}{2}$

(4) $3y = -2x + 12$

27 In $\triangle ABC$, point D is on \overline{AB} , and point E is on \overline{BC} such that $\overline{DE} \parallel \overline{AC}$. If $DB = 2$, $DA = 7$, and $DE = 3$, what is the length of \overline{AC} ?

(1) 8

(3) 10.5

(2) 9

(4) 13.5

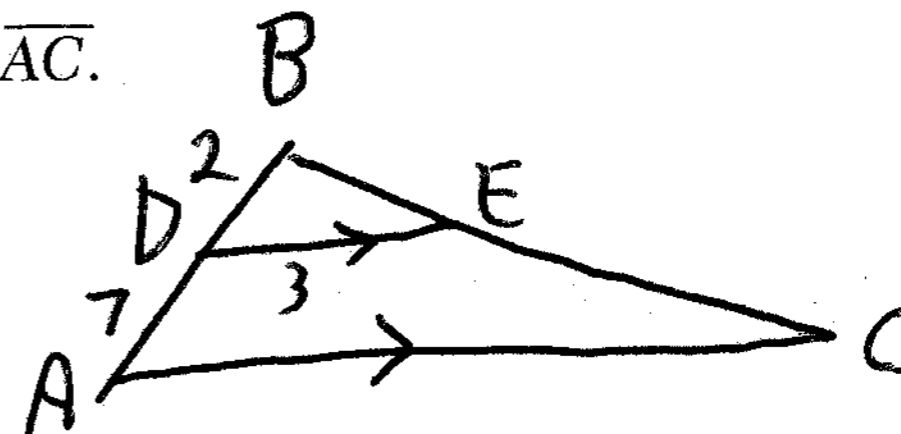

$$\frac{2}{3} = \frac{9}{x}$$
$$\frac{2x}{3} = \frac{27}{2}$$
$$x = 13.5$$

28 In three-dimensional space, two planes are parallel and a third plane intersects both of the parallel planes. The intersection of the planes is a

(1) plane

(3) pair of parallel lines

(2) point

(4) pair of intersecting lines

Part II

Answer all 6 questions in this part. Each correct answer will receive 2 credits. Clearly indicate the necessary steps, including appropriate formula substitutions, diagrams, graphs, charts, etc. For all questions in this part, a correct numerical answer with no work shown will receive only 1 credit. All answers should be written in pen, except for graphs and drawings, which should be done in pencil. [12]

29 In the diagram of $\triangle ABC$ below, $AB = 10$, $BC = 14$, and $AC = 16$. Find the perimeter of the triangle formed by connecting the midpoints of the sides of $\triangle ABC$.

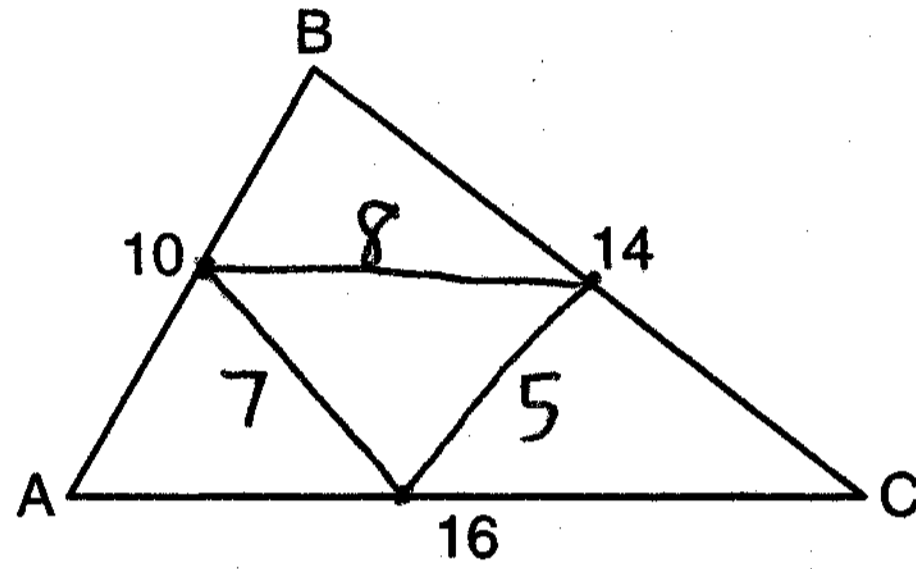

20

30 Using a compass and straightedge, construct a line that passes through point P and is perpendicular to line m . [Leave all construction marks.]

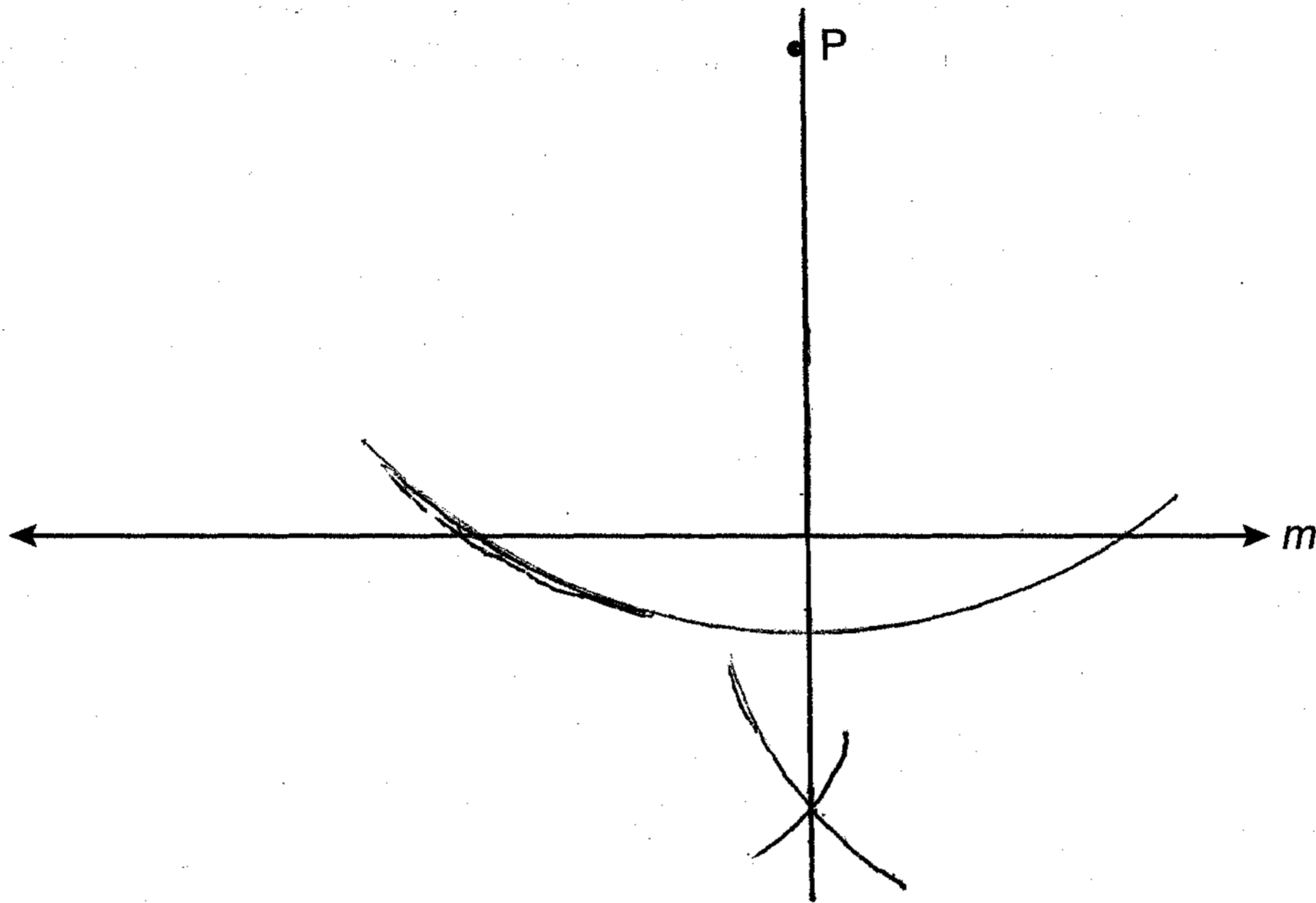

31 Find an equation of the line passing through the point $(5,4)$ and parallel to the line whose equation is $2x + y = 3$.

$$m = \frac{-A}{B} = \frac{-2}{1}$$

$$y = mx + b$$

$$4 = -2(5) + b$$

$$4 = -10 + b$$

$$14 = b$$

$$y = mx + b$$

$$y = -2x + 14$$

32 The length of \overline{AB} is 3 inches. On the diagram below, sketch the points that are equidistant from A and B and sketch the points that are 2 inches from A . Label with an **X** all points that satisfy *both* conditions.

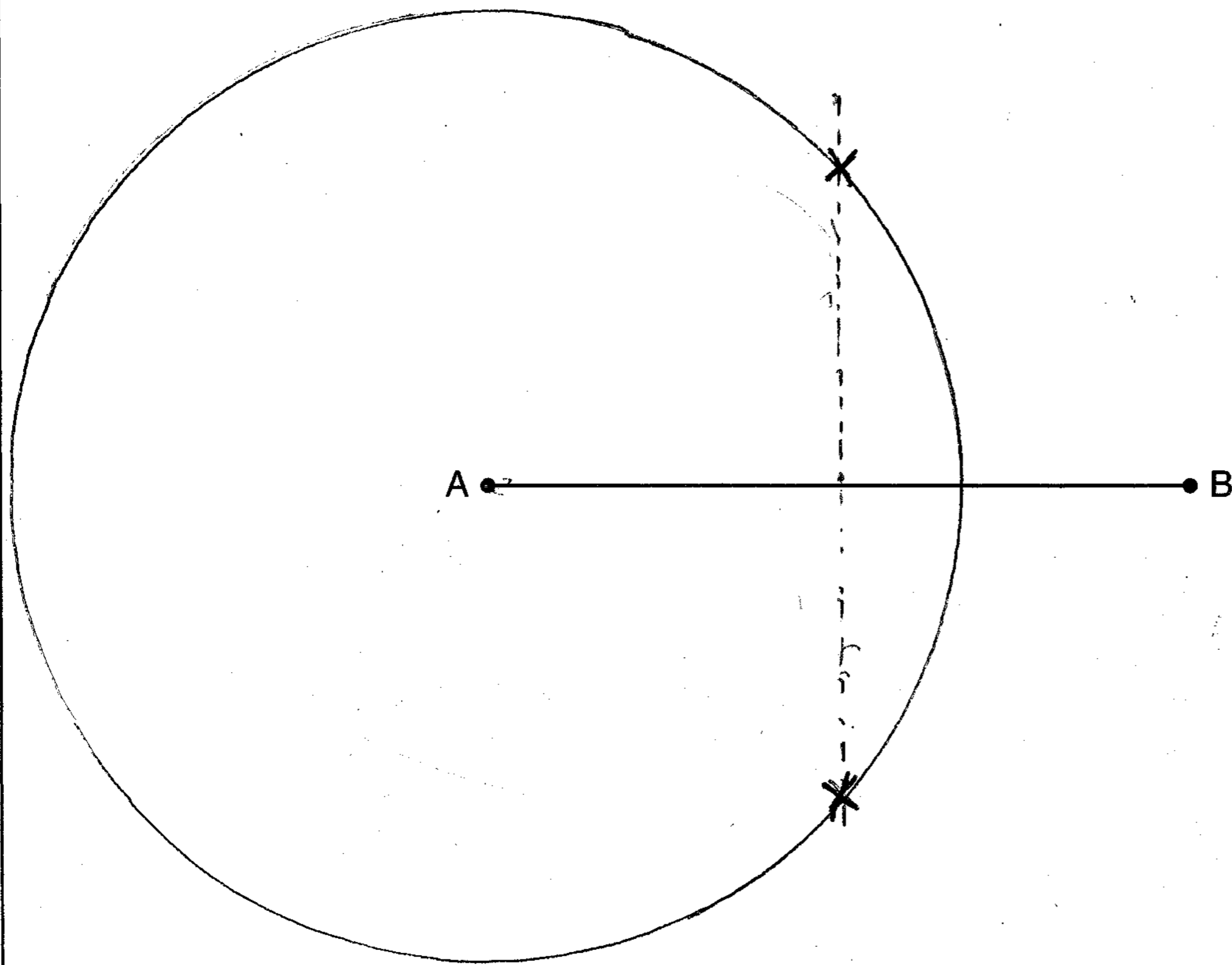

33 Given: Two is an even integer or three is an even integer.

Determine the truth value of this disjunction. Justify your answer.

The first statement is true and the second statement is false. In a disjunction, if either statement is true, the disjunction is true.

34 In the diagram below, $\triangle ABC \sim \triangle EFG$, $m\angle C = 4x + 30$, and $m\angle G = 5x + 10$. Determine the value of x .

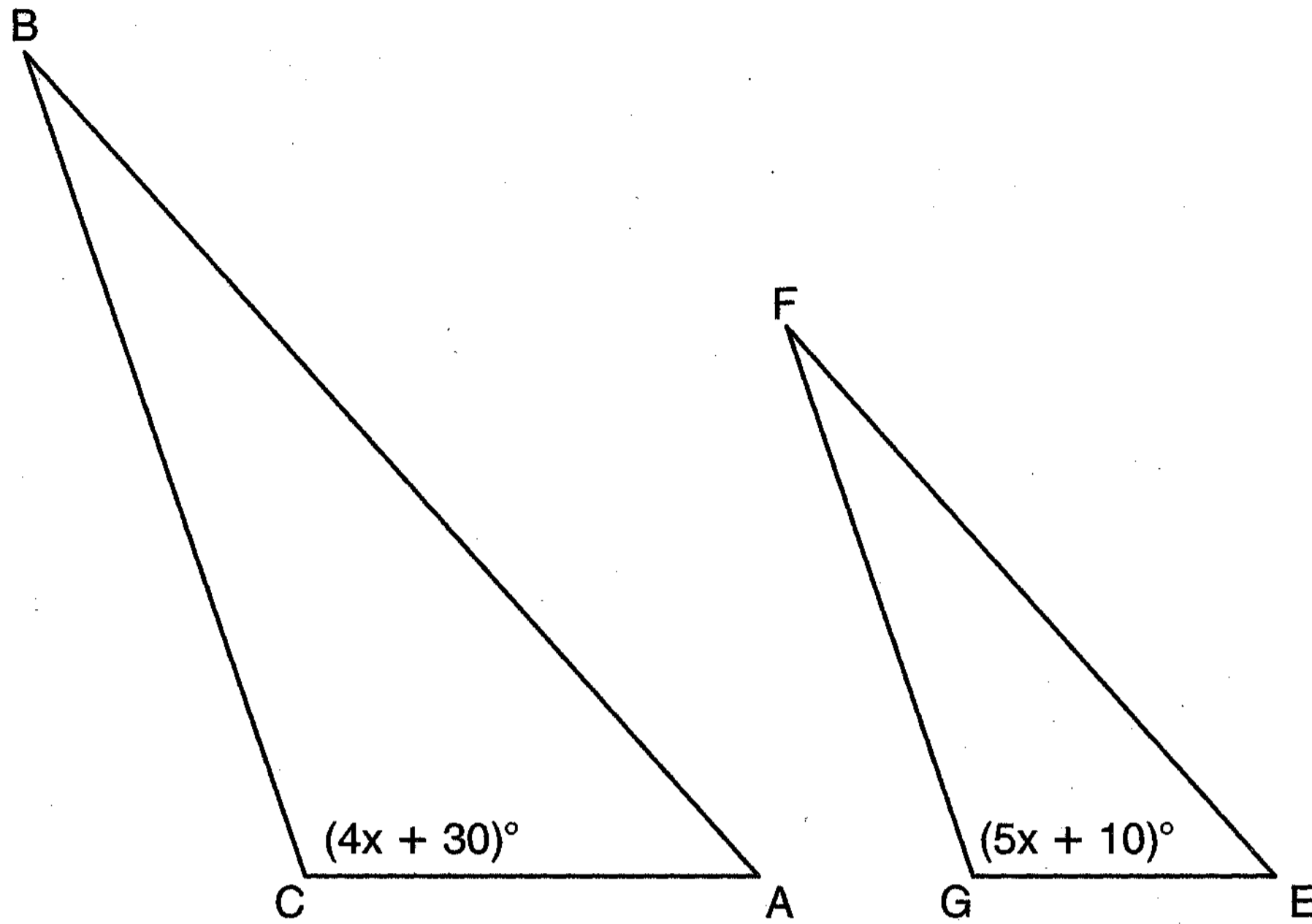

$$4x + 30 = 5x + 10$$
$$20 = x$$

Part III

Answer all 3 questions in this part. Each correct answer will receive 4 credits. Clearly indicate the necessary steps, including appropriate formula substitutions, diagrams, graphs, charts, etc. For all questions in this part, a correct numerical answer with no work shown will receive only 1 credit. All answers should be written in pen, except for graphs and drawings, which should be done in pencil. [12]

- 35 In the diagram below, circles X and Y have two tangents drawn to them from external point T . The points of tangency are C , A , S , and E . The ratio of TA to AC is $1:3$. If $TS = 24$, find the length of \overline{SE} .

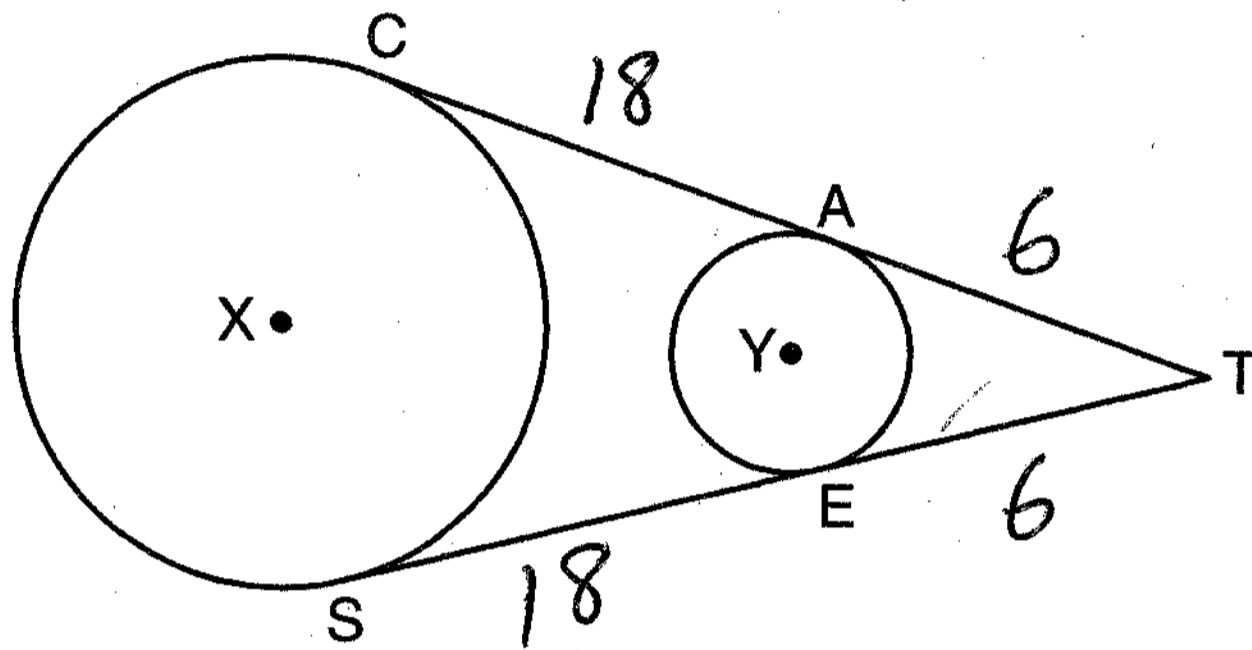

(Not drawn to scale)

$$\frac{1}{4} \times 24 = 6$$

$$\frac{3}{4} \times 24 = 18$$

36 Triangle ABC has coordinates $A(-6,2)$, $B(-3,6)$, and $C(5,0)$. Find the perimeter of the triangle. Express your answer in simplest radical form. [The use of the grid below is optional.]

$$15 + 5\sqrt{5}$$

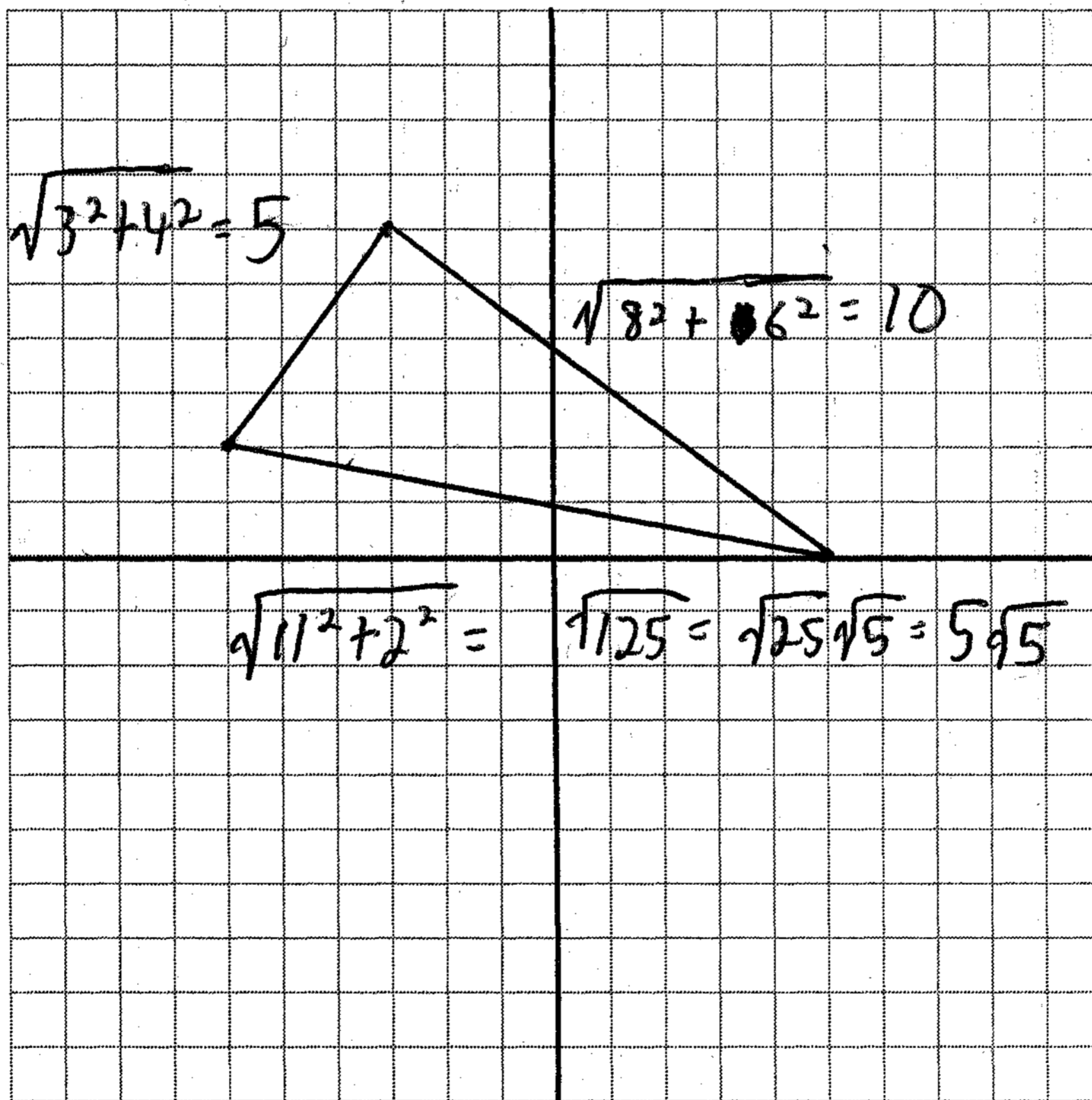

37 The coordinates of the vertices of parallelogram $ABCD$ are $A(-2,2)$, $B(3,5)$, $C(4,2)$, and $D(-1,-1)$. State the coordinates of the vertices of parallelogram $A''B''C''D''$ that result from the transformation $r_{y\text{-axis}} \circ T_{2,-3}$. [The use of the set of axes below is optional.]

$A(-2,2)$	$A'(0,-1)$	$A''(0,-1)$
$B(3,5)$	$B'(5,2)$	$B''(-5,2)$
$C(4,2)$	$C'(6,-1)$	$C''(-6,-1)$
$D(-1,-1)$	$D'(1,-4)$	$D''(-1,-4)$

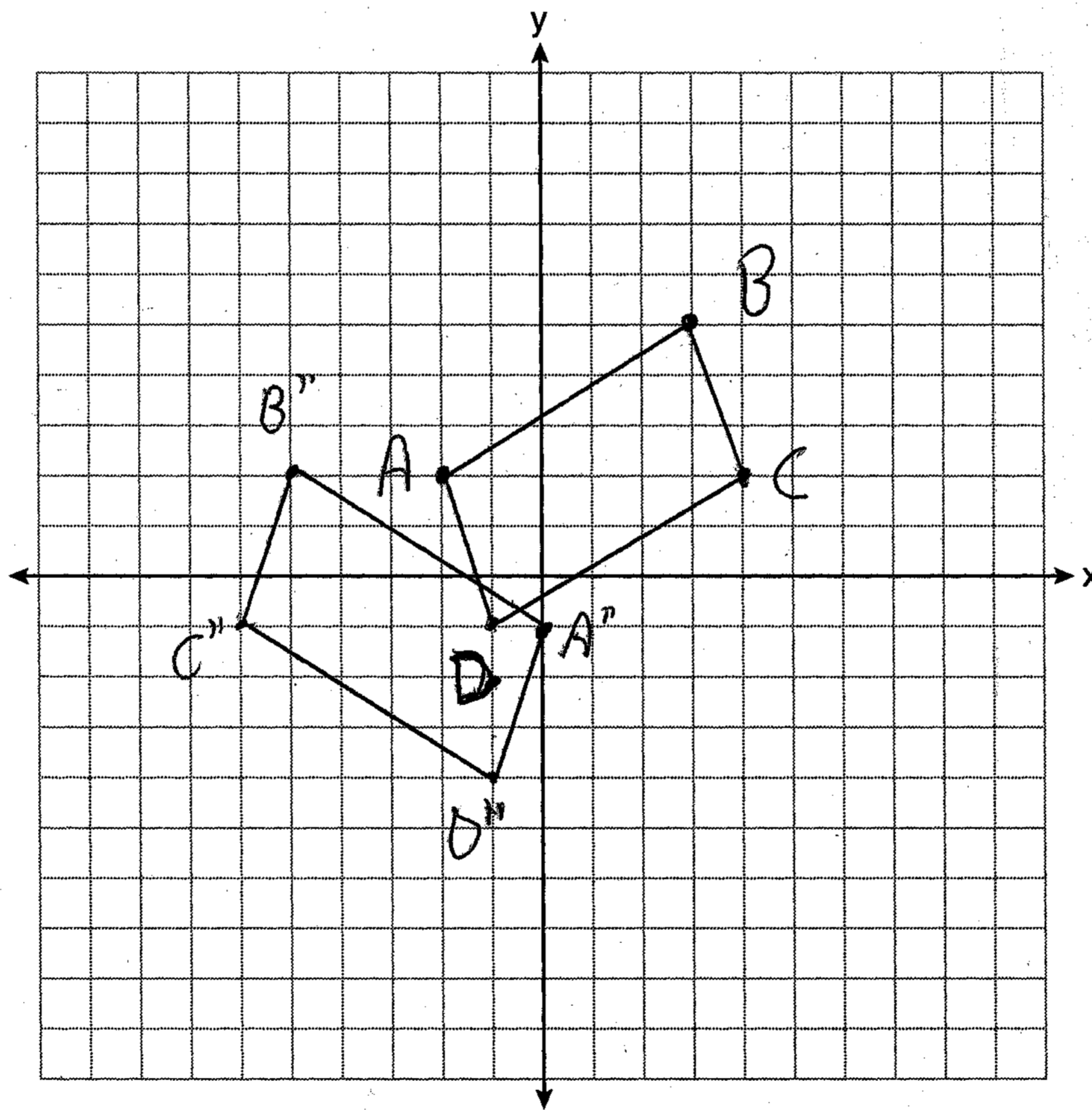

Part IV

Answer the question in this part. A correct answer will receive 6 credits. Clearly indicate the necessary steps, including appropriate formula substitutions, diagrams, graphs, charts, etc. A correct numerical answer with no work shown will receive only 1 credit. The answer should be written in pen. [6]

38 Given: $\triangle ABC$ and $\triangle EDC$, C is the midpoint of \overline{BD} and \overline{AE}

Prove: $\overline{AB} \parallel \overline{DE}$

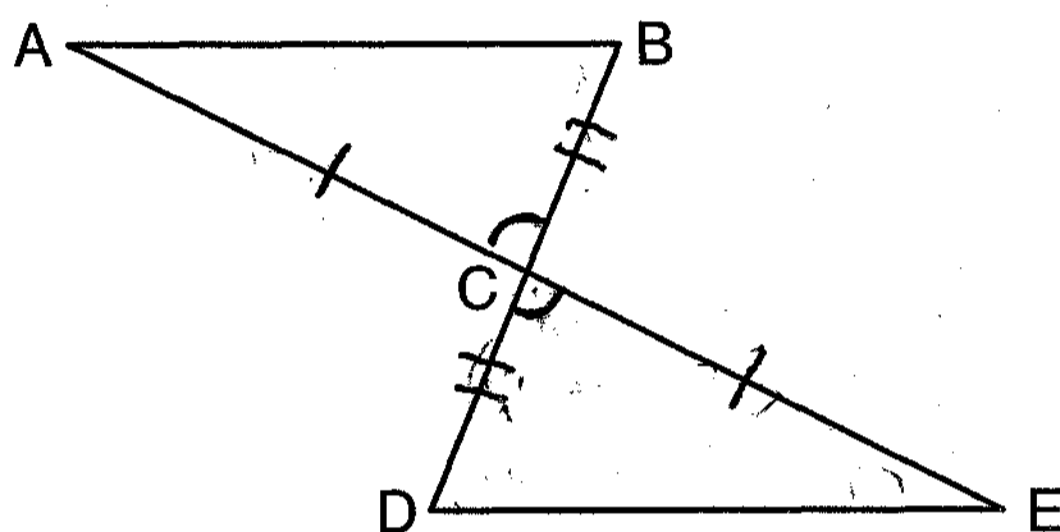

Statement	Reason
① $\triangle ABC$, $\triangle EDC$, C is the midpoint of \overline{BD} and \overline{AE} .	① Given
② $\overline{AC} \cong \overline{EC}$ and $\overline{BC} \cong \overline{DC}$	② Definition of midpoint
③ $\angle ACB \cong \angle ECD$	③ Vertical angles
④ $\triangle ABC \cong \triangle EDC$	④ SAS
⑤ $\angle CDE \cong \angle CBA$	⑤ CPCTC
⑥ \overline{BD} is a transversal intersecting \overline{AB} and \overline{ED}	⑥ Definition of transversal
⑦ $\overline{AB} \parallel \overline{DE}$	⑦ Because $\angle CDE$ and $\angle CBA$ are congruent alternate interior angles.