

The University of the State of New York
REGENTS HIGH SCHOOL EXAMINATION

GEOMETRY

Tuesday, June 16, 2009—9:15 a.m. to 12:15 p.m., only

Student Name: _____

School Name: _____

Print your name and the name of your school on the lines above.

This examination has four parts, with a total of 38 questions. You must answer all questions in this examination. Record your answers to the Part I multiple-choice questions, using a No. 2 pencil, on the separate answer sheet provided to you. Write your answers to the questions in Parts II, III, and IV directly in this test booklet. All work for Parts II, III, and IV should be written in pen, except graphs and drawings, which should be done in pencil. Clearly indicate the necessary steps, including appropriate formula substitutions, diagrams, graphs, charts, etc.

The formulas that you may need to answer some questions in this examination are found at the end of the examination. This sheet is perforated so you may remove it from this booklet.

Scrap paper is not permitted for any part of this examination, but you may use the blank spaces in this booklet as scrap paper. A perforated sheet of scrap graph paper is provided at the end of this booklet for any question for which graphing may be helpful but is not required. You may remove this sheet from this booklet. Any work done on this sheet of scrap graph paper will *not* be scored.

When you have completed the examination, you must sign the statement printed at the end of the answer sheet, indicating that you had no unlawful knowledge of the questions or answers prior to the examination and that you have neither given nor received assistance in answering any of the questions during the examination. Your answer sheet cannot be accepted if you fail to sign this declaration.

Notice . . .

A graphing calculator, a straightedge (ruler), and a compass must be available for you to use while taking this examination.

The use of any communications device is strictly prohibited when taking this examination. If you use any communications device, no matter how briefly, your examination will be invalidated and no score will be calculated for you.

DO NOT OPEN THIS EXAMINATION BOOKLET UNTIL THE SIGNAL IS GIVEN.

Part I

Answer all 28 questions in this part. Each correct answer will receive 2 credits. No partial credit will be allowed. For each question, record your answer, using a No. 2 pencil, on the separate answer sheet provided to you. [56]

Use this space for computations.

- 1 Juliann plans on drawing $\triangle ABC$, where the measure of $\angle A$ can range from 50° to 60° and the measure of $\angle B$ can range from 90° to 100° . Given these conditions, what is the correct range of measures possible for $\angle C$?

- (1) 20° to 40° (3) 80° to 90°
(2) 30° to 50° (4) 120° to 130°

- 2 In the diagram of $\triangle ABC$ and $\triangle DEF$ below, $\overline{AB} \cong \overline{DE}$, $\angle A \cong \angle D$, and $\angle B \cong \angle E$.

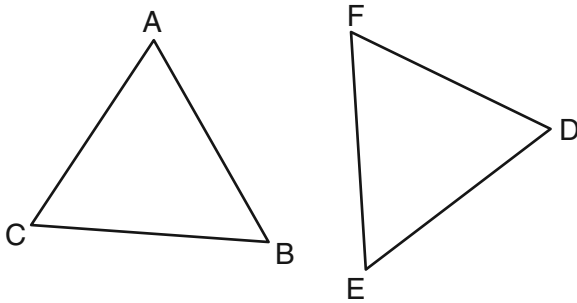

Which method can be used to prove $\triangle ABC \cong \triangle DEF$?

- (1) SSS (3) ASA
(2) SAS (4) HL

Use this space for
computations.

- 3 In the diagram below, under which transformation will $\triangle A'B'C'$ be the image of $\triangle ABC$?

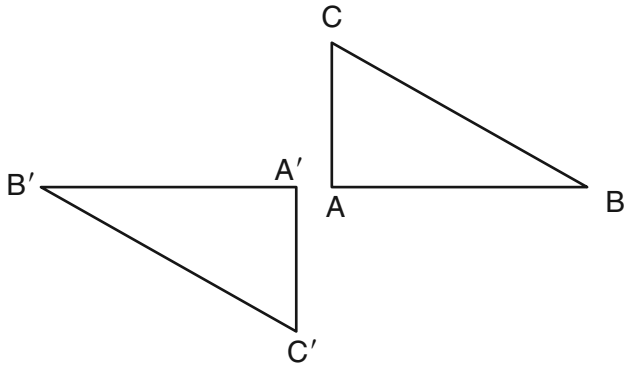

- (1) rotation
(2) dilation
(3) translation
(4) glide reflection
- 4 The lateral faces of a regular pyramid are composed of
- (1) squares
(2) rectangles
(3) congruent right triangles
(4) congruent isosceles triangles
- 5 Point A is located at $(4, -7)$. The point is reflected in the x -axis. Its image is located at
- (1) $(-4, 7)$
(2) $(-4, -7)$
(3) $(4, 7)$
(4) $(7, -4)$

**Use this space for
computations.**

- 6** In the diagram of circle O below, chords \overline{AB} and \overline{CD} are parallel, and \overline{BD} is a diameter of the circle.

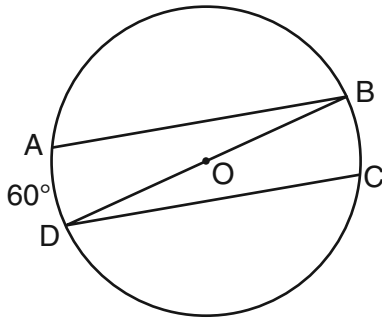

If $mAD = 60$, what is $m\angle CDB$?

- (1) 20 (3) 60
(2) 30 (4) 120

- 7** What is an equation of the line that passes through the point $(-2,5)$ and is perpendicular to the line whose equation is $y = \frac{1}{2}x + 5$?

- (1) $y = 2x + 1$ (3) $y = 2x + 9$
(2) $y = -2x + 1$ (4) $y = -2x - 9$

Use this space for computations.

- 8 After a composition of transformations, the coordinates $A(4,2)$, $B(4,6)$, and $C(2,6)$ become $A''(-2,-1)$, $B''(-2,-3)$, and $C''(-1,-3)$, as shown on the set of axes below.

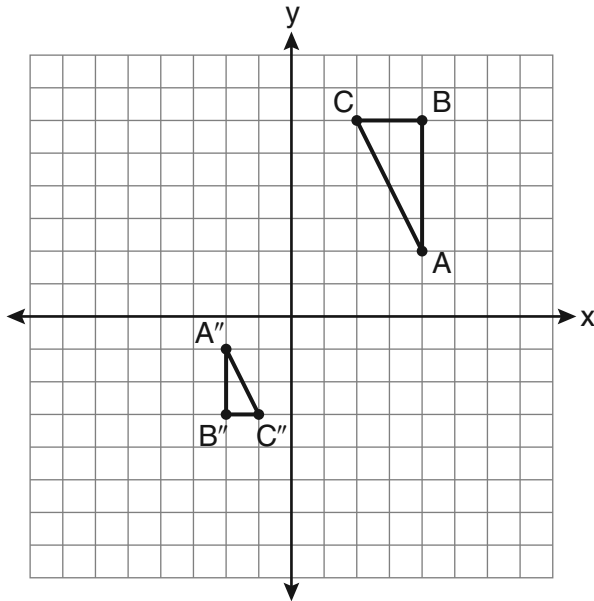

Which composition of transformations was used?

- (1) $R_{180^\circ} \circ D_2$ (3) $D_{\frac{1}{2}} \circ R_{180^\circ}$
(2) $R_{90^\circ} \circ D_2$ (4) $D_{\frac{1}{2}} \circ R_{90^\circ}$

- 9 In an equilateral triangle, what is the difference between the sum of the exterior angles and the sum of the interior angles?

- (1) 180° (3) 90°
(2) 120° (4) 60°

**Use this space for
computations.**

10 What is an equation of a circle with its center at $(-3,5)$ and a radius of 4?

(1) $(x - 3)^2 + (y + 5)^2 = 16$

(2) $(x + 3)^2 + (y - 5)^2 = 16$

(3) $(x - 3)^2 + (y + 5)^2 = 4$

(4) $(x + 3)^2 + (y - 5)^2 = 4$

11 In $\triangle ABC$, $m\angle A = 95$, $m\angle B = 50$, and $m\angle C = 35$. Which expression correctly relates the lengths of the sides of this triangle?

(1) $AB < BC < CA$

(3) $AC < BC < AB$

(2) $AB < AC < BC$

(4) $BC < AC < AB$

12 In a coordinate plane, how many points are both 5 units from the origin and 2 units from the x -axis?

(1) 1

(3) 3

(2) 2

(4) 4

13 What is the contrapositive of the statement, "If I am tall, then I will bump my head"?

(1) If I bump my head, then I am tall.

(2) If I do not bump my head, then I am tall.

(3) If I am tall, then I will not bump my head.

(4) If I do not bump my head, then I am not tall.

Use this space for
computations.

- 14 In the diagram of $\triangle ABC$ below, Jose found centroid P by constructing the three medians. He measured \overline{CF} and found it to be 6 inches.

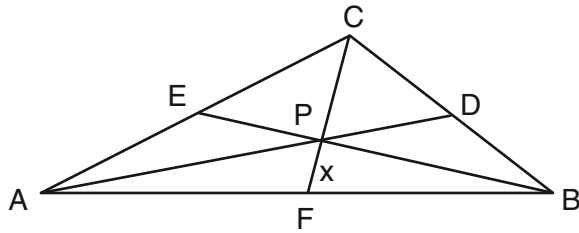

If $PF = x$, which equation can be used to find x ?

- (1) $x + x = 6$ (3) $3x + 2x = 6$
(2) $2x + x = 6$ (4) $x + \frac{2}{3}x = 6$
- 15 In the diagram below, the length of the legs \overline{AC} and \overline{BC} of right triangle ABC are 6 cm and 8 cm, respectively. Altitude \overline{CD} is drawn to the hypotenuse of $\triangle ABC$.

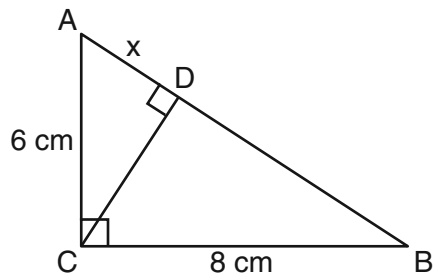

What is the length of \overline{AD} to the nearest tenth of a centimeter?

- (1) 3.6 (3) 6.4
(2) 6.0 (4) 4.0

Use this space for computations.

- 16 In the diagram below, tangent \overline{AB} and secant \overline{ACD} are drawn to circle O from an external point A , $AB = 8$, and $AC = 4$.

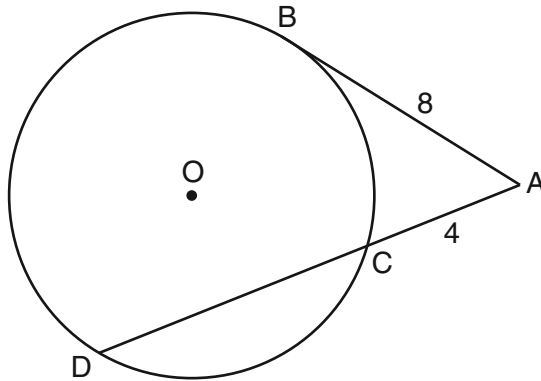

What is the length of \overline{CD} ?

- (1) 16 (3) 12
(2) 13 (4) 10
- 17 In the diagram of $\triangle ABC$ and $\triangle EDC$ below, \overline{AE} and \overline{BD} intersect at C , and $\angle CAB \cong \angle CED$.

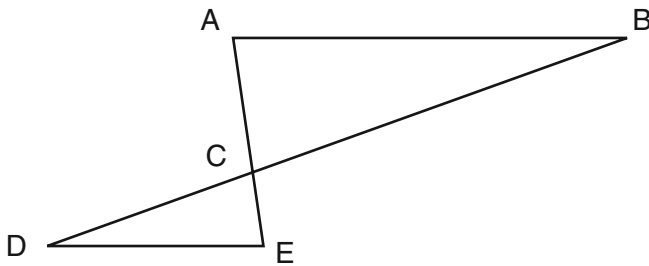

Which method can be used to show that $\triangle ABC$ must be similar to $\triangle EDC$?

- (1) SAS (3) SSS
(2) AA (4) HL

Use this space for
computations.

18 Point P is on line m . What is the total number of planes that are perpendicular to line m and pass through point P ?

- (1) 1 (3) 0
(2) 2 (4) infinite

19 Square $LMNO$ is shown in the diagram below.

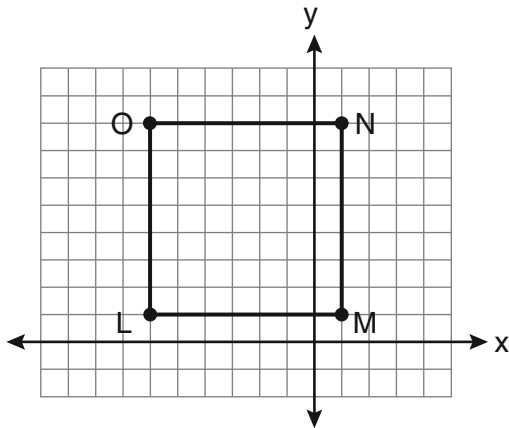

What are the coordinates of the midpoint of diagonal \overline{LN} ?

- (1) $(4\frac{1}{2}, -2\frac{1}{2})$ (3) $(-2\frac{1}{2}, 3\frac{1}{2})$
(2) $(-3\frac{1}{2}, 3\frac{1}{2})$ (4) $(-2\frac{1}{2}, 4\frac{1}{2})$

Use this space for
computations.

20 Which graph represents a circle with the equation
 $(x - 5)^2 + (y + 1)^2 = 9$?

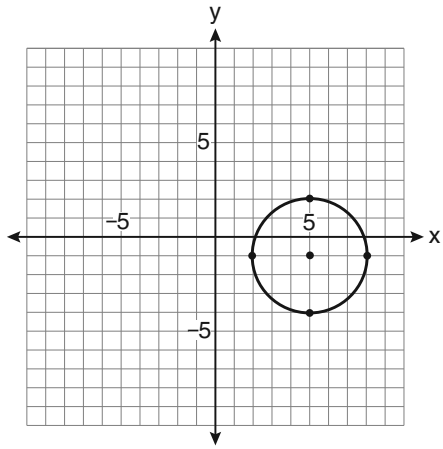

(1)

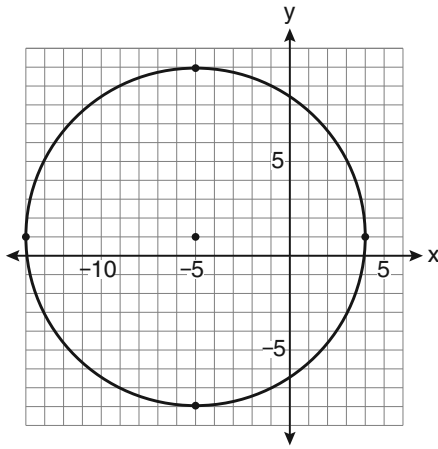

(3)

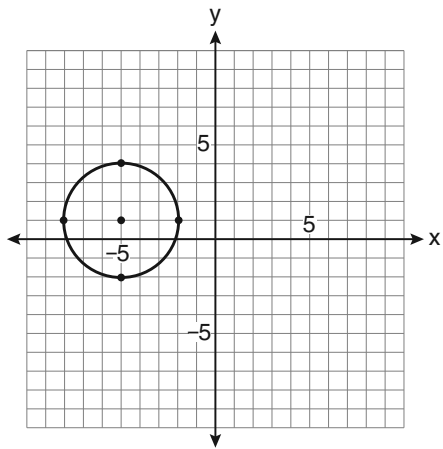

(2)

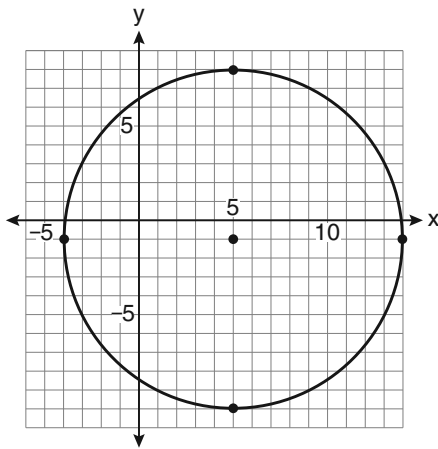

(4)

Use this space for computations.

- 21** In the diagram below, a right circular cone has a diameter of 8 inches and a height of 12 inches.

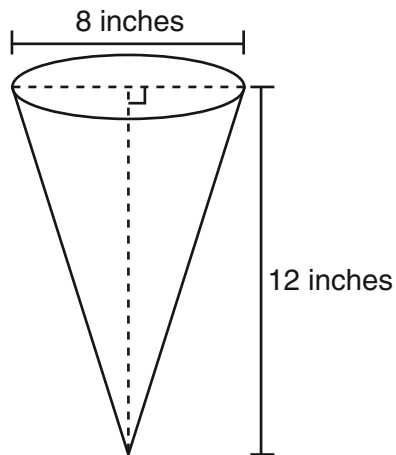

What is the volume of the cone to the *nearest cubic inch*?

- (1) 201 (3) 603
(2) 481 (4) 804
-
- 22** A circle is represented by the equation $x^2 + (y + 3)^2 = 13$. What are the coordinates of the center of the circle and the length of the radius?
- (1) (0,3) and 13 (3) (0,-3) and 13
(2) (0,3) and $\sqrt{13}$ (4) (0,-3) and $\sqrt{13}$

23 Given the system of equations:

$$y = x^2 - 4x$$

$$x = 4$$

The number of points of intersection is

- (1) 1 (3) 3
(2) 2 (4) 0

24 Side \overline{PQ} of $\triangle PQR$ is extended through Q to point T . Which statement is *not* always true?

- (1) $m\angle RQT > m\angle R$ (3) $m\angle RQT = m\angle P + m\angle R$
(2) $m\angle RQT > m\angle P$ (4) $m\angle RQT > m\angle PQR$

25 Which illustration shows the correct construction of an angle bisector?

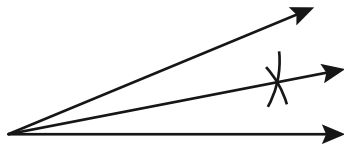

(1)

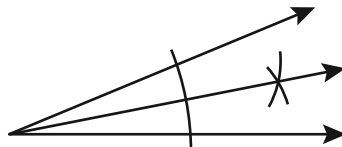

(3)

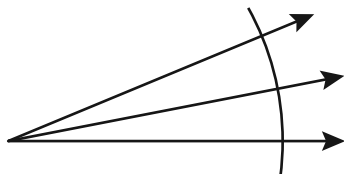

(2)

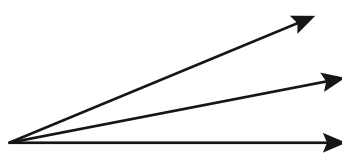

(4)

**Use this space for
computations.**

26 Which equation represents a line perpendicular to the line whose equation is $2x + 3y = 12$?

(1) $6y = -4x + 12$

(3) $2y = -3x + 6$

(2) $2y = 3x + 6$

(4) $3y = -2x + 12$

27 In $\triangle ABC$, point D is on \overline{AB} , and point E is on \overline{BC} such that $\overline{DE} \parallel \overline{AC}$. If $DB = 2$, $DA = 7$, and $DE = 3$, what is the length of \overline{AC} ?

(1) 8

(3) 10.5

(2) 9

(4) 13.5

28 In three-dimensional space, two planes are parallel and a third plane intersects both of the parallel planes. The intersection of the planes is a

(1) plane

(3) pair of parallel lines

(2) point

(4) pair of intersecting lines

Part II

Answer all 6 questions in this part. Each correct answer will receive 2 credits. Clearly indicate the necessary steps, including appropriate formula substitutions, diagrams, graphs, charts, etc. For all questions in this part, a correct numerical answer with no work shown will receive only 1 credit. All answers should be written in pen, except for graphs and drawings, which should be done in pencil. [12]

- 29 In the diagram of $\triangle ABC$ below, $AB = 10$, $BC = 14$, and $AC = 16$. Find the perimeter of the triangle formed by connecting the midpoints of the sides of $\triangle ABC$.

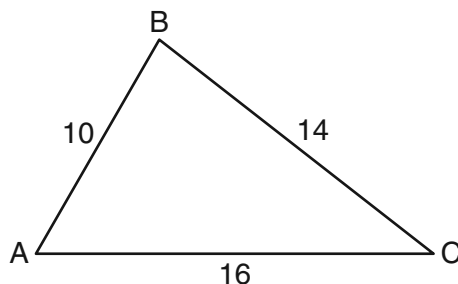

- 30** Using a compass and straightedge, construct a line that passes through point P and is perpendicular to line m . [Leave all construction marks.]

• P



- 31** Find an equation of the line passing through the point $(5,4)$ and parallel to the line whose equation is $2x + y = 3$.

32 The length of \overline{AB} is 3 inches. On the diagram below, sketch the points that are equidistant from A and B and sketch the points that are 2 inches from A . Label with an **X** all points that satisfy *both* conditions.



33 Given: Two is an even integer or three is an even integer.

Determine the truth value of this disjunction. Justify your answer.

34 In the diagram below, $\triangle ABC \sim \triangle EFG$, $m\angle C = 4x + 30$, and $m\angle G = 5x + 10$. Determine the value of x .

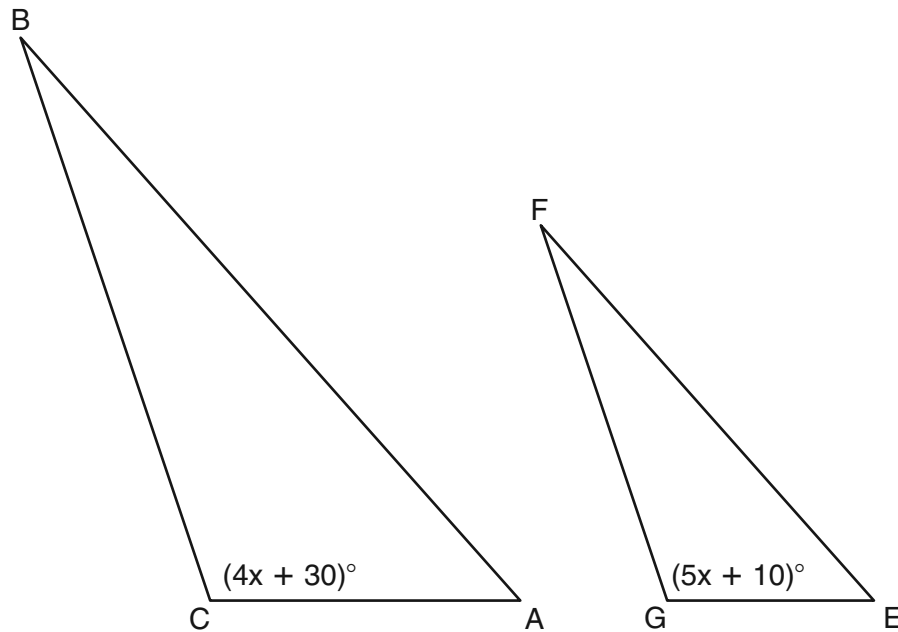

Part III

Answer all 3 questions in this part. Each correct answer will receive 4 credits. Clearly indicate the necessary steps, including appropriate formula substitutions, diagrams, graphs, charts, etc. For all questions in this part, a correct numerical answer with no work shown will receive only 1 credit. All answers should be written in pen, except for graphs and drawings, which should be done in pencil. [12]

- 35 In the diagram below, circles X and Y have two tangents drawn to them from external point T . The points of tangency are C , A , S , and E . The ratio of TA to AC is 1:3. If $TS = 24$, find the length of \overline{SE} .

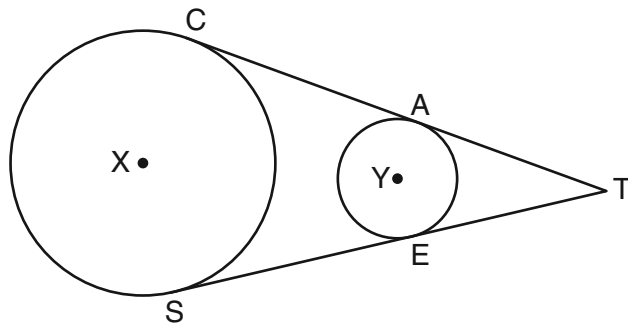

(Not drawn to scale)

36 Triangle ABC has coordinates $A(-6,2)$, $B(-3,6)$, and $C(5,0)$. Find the perimeter of the triangle. Express your answer in simplest radical form. [The use of the grid below is optional.]

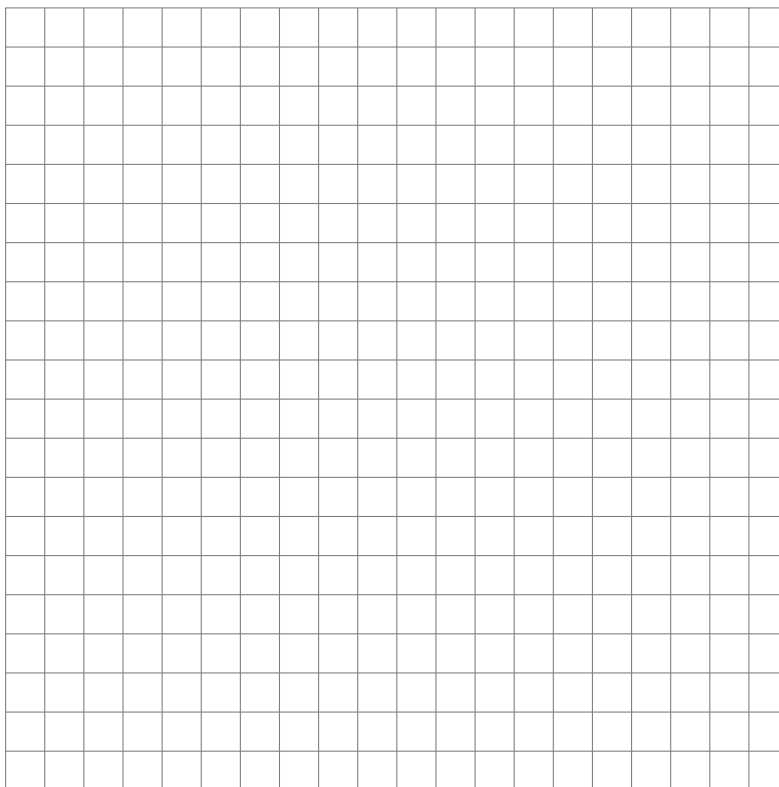

- 37 The coordinates of the vertices of parallelogram $ABCD$ are $A(-2,2)$, $B(3,5)$, $C(4,2)$, and $D(-1,-1)$. State the coordinates of the vertices of parallelogram $A''B''C''D''$ that result from the transformation $r_{y\text{-axis}} \circ T_{2,-3}$. [The use of the set of axes below is optional.]

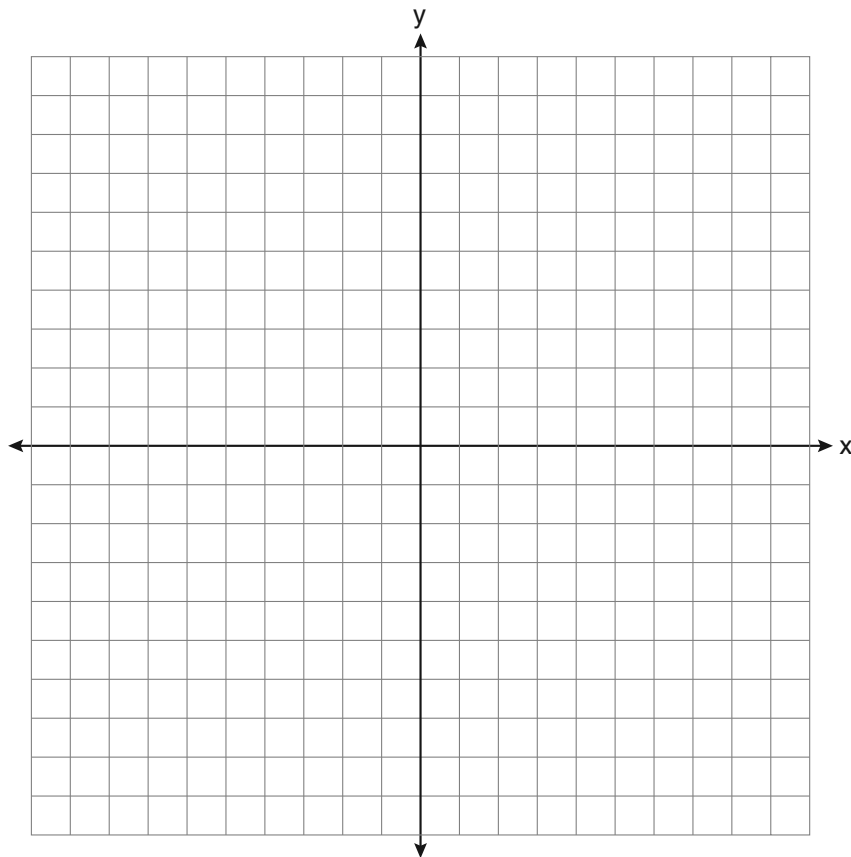

Part IV

Answer the question in this part. A correct answer will receive 6 credits. Clearly indicate the necessary steps, including appropriate formula substitutions, diagrams, graphs, charts, etc. A correct numerical answer with no work shown will receive only 1 credit. The answer should be written in pen. [6]

38 Given: $\triangle ABC$ and $\triangle EDC$, C is the midpoint of \overline{BD} and \overline{AE}

Prove: $\overline{AB} \parallel \overline{DE}$

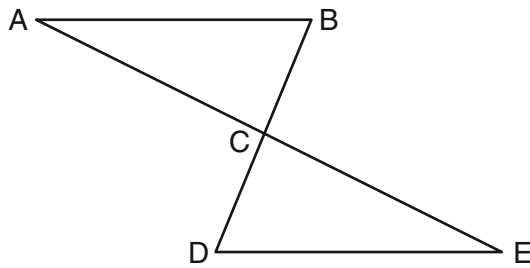

Reference Sheet

Tear Here

Volume	Cylinder	$V = Bh$ where B is the area of the base
	Pyramid	$V = \frac{1}{3}Bh$ where B is the area of the base
	Right Circular Cone	$V = \frac{1}{3}Bh$ where B is the area of the base
	Sphere	$V = \frac{4}{3}\pi r^3$

Lateral Area (L)	Right Circular Cylinder	$L = 2\pi rh$
	Right Circular Cone	$L = \pi rl$ where l is the slant height

Surface Area	Sphere	$SA = 4\pi r^2$
--------------	--------	-----------------

Tear Here

Scrap Graph Paper — This sheet will *not* be scored.

Tear Here

Tear Here

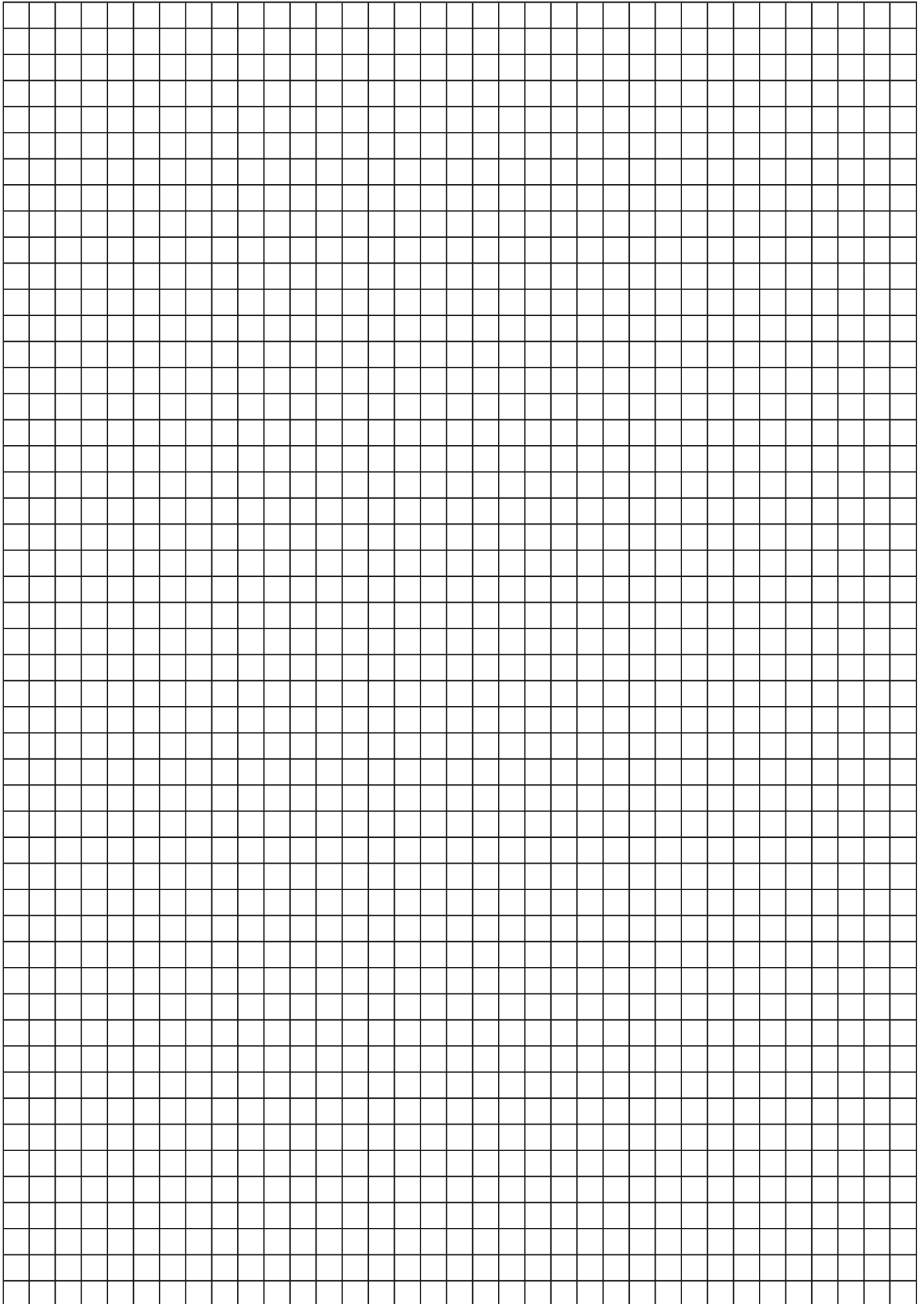

Scrap Graph Paper — This sheet will *not* be scored.

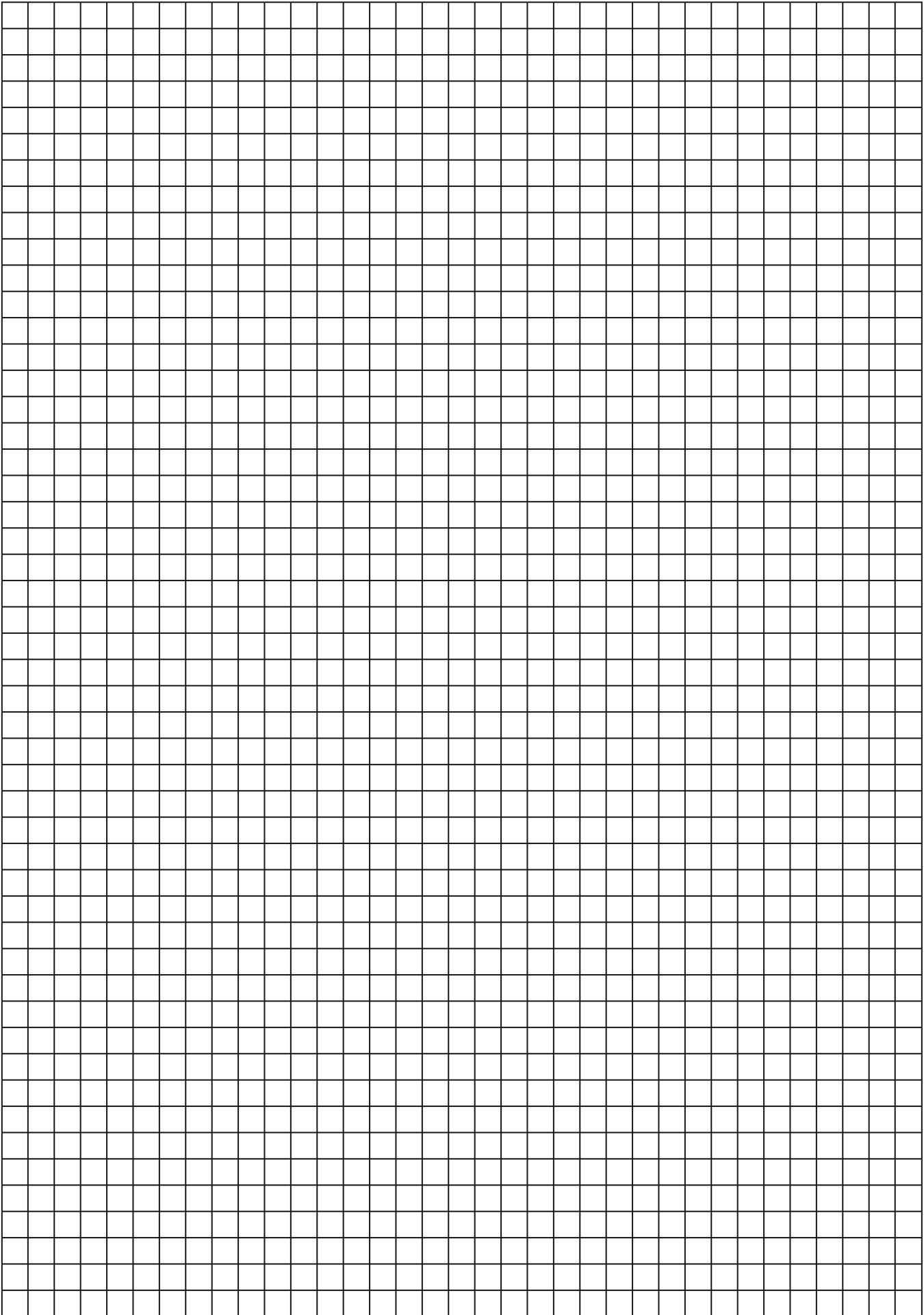

Tear Here

Tear Here

FOR TEACHERS ONLY

The University of the State of New York

REGENTS HIGH SCHOOL EXAMINATION

GEOMETRY

Tuesday, June 16, 2009 — 9:15 a.m. to 12:15 p.m., only

SCORING KEY AND RATING GUIDE

Mechanics of Rating

The following procedures are to be followed for scoring student answer papers for the Regents Examination in Geometry. More detailed information about scoring is provided in the publication *Information Booklet for Scoring the Regents Examination in Geometry*.

Use only a No. 2 pencil in rating the Regents Examination in Geometry. Do *not* attempt to correct the student's work by making insertions or changes of any kind. Scoring overlays have been included in the package of scoring materials and must be used to score Part I, the multiple-choice section. When scoring the examination:

- **cut out** the rectangular space on the bottom of the scoring overlay to record the total Part I score
- **do not** punch holes in the scoring overlay
- **do not** make any marks on the answer sheet, other than in the spaces provided for recording scores
- **do not** machine scan the answer sheets. Marking up or scanning these answer sheets will interfere with the score collection.

Unless otherwise specified, mathematically correct variations in the answers will be allowed. Units need not be given when the wording of the questions allows such omissions.

Each student's answer paper is to be scored by a minimum of three mathematics teachers. On the back of the student's answer sheet, raters must enter their initials in the boxes next to the questions they have scored and also write their name in the box under the heading "Rater's/Scorer's Name."

Raters should record the student's scores for all questions and the total raw score on the student's answer sheet. Make a careful record to be retained in the school of the total raw score earned by each student. The State Education Department will provide a recordkeeping form for this purpose as part of the detailed directions for administering and scoring the June 2009 Regents Examination in Geometry.

The conversion chart for the Regents Examination in Geometry will be posted on the Department's web site <http://www.emsc.nysed.gov/osa/> no later than Rating Day, Thursday, June 25, 2009.

GEOMETRY – *continued*

Part I

Allow a total of 56 credits, 2 credits for each of the following:

(1) 1	(8) 3	(15) 1	(22) 4
(2) 3	(9) 1	(16) 3	(23) 1
(3) 1	(10) 2	(17) 2	(24) 4
(4) 4	(11) 2	(18) 1	(25) 3
(5) 3	(12) 4	(19) 4	(26) 2
(6) 2	(13) 4	(20) 1	(27) 4
(7) 2	(14) 2	(21) 1	(28) 3

Part II

For each question, use the specific criteria to award a maximum of two credits. Unless otherwise specified, mathematically correct alternative solutions should be awarded appropriate credit.

(29) [2] 20, and appropriate work is shown.

[1] Appropriate work is shown, but one computational error is made.

or

[1] Appropriate work is shown, but one conceptual error is made.

or

[1] 20, but no work is shown.

[0] A zero response is completely incorrect, irrelevant, or incoherent or is a correct response that was obtained by an obviously incorrect procedure.

(30) [2] A correct construction is drawn showing all appropriate arcs, and the perpendicular line is drawn.

[1] Appropriate work is shown, but one construction error is made, such as not drawing the perpendicular line.

or

[1] Appropriate work is shown, but one conceptual error is made.

[0] A drawing that is not an appropriate construction is shown.

or

[0] A zero response is completely incorrect, irrelevant, or incoherent or is a correct response that was obtained by an obviously incorrect procedure.

GEOMETRY – *continued*

(31) [2] $y - 4 = -2(x - 5)$ or an equivalent equation, and appropriate work is shown.

[1] Appropriate work is shown, but one computational error is made.

or

[1] Appropriate work is shown, but one conceptual error is made, such as leaving the answer as $\frac{y - 4}{x - 5} = \frac{-2}{1}$, which has a domain restriction.

or

[1] $y - 4 = -2(x - 5)$ or an equivalent equation, but no work is shown.

[0] A zero response is completely incorrect, irrelevant, or incoherent or is a correct response that was obtained by an obviously incorrect procedure.

(32) [2] Both loci are sketched correctly, and the two points of intersection are labeled with an X.

[1] Both loci are sketched correctly, but the points of intersection are not labeled or are labeled incorrectly.

or

[1] Appropriate work is shown, but one conceptual error is made, but appropriate points of intersection are labeled.

[0] A zero response is completely incorrect, irrelevant, or incoherent or is a correct response that was obtained by an obviously incorrect procedure.

GEOMETRY – *continued*

(33) [2] True, and an appropriate justification is written.

[1] True, but the justification is incorrect.

or

[1] One conceptual error is made in evaluating the disjunction, but an appropriate justification is written.

[0] True, but no justification is written.

or

[0] A zero response is completely incorrect, irrelevant, or incoherent or is a correct response that was obtained by an obviously incorrect procedure.

(34) [2] 20, and appropriate work is shown.

[1] Appropriate work is shown, but one computational error is made.

or

[1] Appropriate work is shown, but one conceptual error is made.

or

[1] 20, but no work is shown.

[0] A zero response is completely incorrect, irrelevant, or incoherent or is a correct response that was obtained by an obviously incorrect procedure.

Part III

For each question, use the specific criteria to award a maximum of four credits. Unless otherwise specified, mathematically correct alternative solutions should be awarded appropriate credit.

(35) [4] 18, and appropriate work is shown, such as $3x + x = 24$.

[3] Appropriate work is shown, but one computational error is made.

or

[3] $x = 6$, and appropriate work is shown, but \overline{SE} is not found or is found incorrectly.

[2] Appropriate work is shown, but two or more computational errors are made.

or

[2] Appropriate work is shown, but one conceptual error is made.

[1] Appropriate work is shown, but one conceptual error and one computational error are made.

or

[1] 18, but no work is shown.

[0] A zero response is completely incorrect, irrelevant, or incoherent or is a correct response that was obtained by an obviously incorrect procedure.

(36) [4] $15 + 5\sqrt{5}$, and appropriate work is shown.

[3] Appropriate work is shown, but one computational error is made.

or

[3] Appropriate work is shown, but the perimeter is not expressed in simplest radical form.

or

[3] Appropriate work is shown to find the length of all three sides, but the perimeter is not found.

[2] Appropriate work is shown, but two or more computational errors are made.

or

[2] Appropriate work is shown, but one conceptual error is made.

or

[2] Appropriate work is shown to find the lengths of two sides, but no further correct work is shown.

[1] Appropriate work is shown, but one conceptual error and one computational error are made.

or

[1] Appropriate work is shown to find the length of one side, but no further correct work is shown.

or

[1] $15 + 5\sqrt{5}$, but no work is shown.

[0] A zero response is completely incorrect, irrelevant, or incoherent or is a correct response that was obtained by an obviously incorrect procedure.

GEOMETRY – *continued*

(37) [4] $A''(0,-1)$, $B''(-5,2)$, $C''(-6,-1)$, and $D''(-1,-4)$, and appropriate work is shown.

[3] The composite transformation is graphed and labeled correctly, but the coordinates are not stated or are stated incorrectly.

or

[3] Appropriate work is shown, but one computational or graphing error is made.

[2] Appropriate work is shown, but two or more computational or graphing errors are made.

or

[2] Appropriate work is shown, but one conceptual error is made, such as performing the reflection before the translation.

[1] Appropriate work is shown, but one conceptual error and one computational or graphing error are made.

or

[1] $A''(0,-1)$, $B''(-5,2)$, $C''(-6,-1)$, and $D''(-1,-4)$, but no work is shown.

[0] A zero response is completely incorrect, irrelevant, or incoherent or is a correct response that was obtained by an obviously incorrect procedure.

Part IV

For this question, use the specific criteria to award a maximum of six credits. Unless otherwise specified, mathematically correct alternative solutions should be awarded appropriate credit.

(38) [6] A complete and correct proof that includes a concluding statement is written.

[5] A proof is written that demonstrates a thorough understanding of the method of proof and contains no conceptual errors, but one statement or reason is missing or incorrect, or no concluding statement is written.

or

[5] $\angle A \cong \angle E$ or $\angle B \cong \angle D$ is proven, but no further correct work is shown.

[4] A proof is written that demonstrates a good understanding of the method of proof and contains no conceptual errors, but two statements or reasons are missing or incorrect.

or

[4] $\triangle ABC \cong \triangle EDC$ is proven, but no further correct work is shown.

[3] A proof is written that demonstrates a good understanding of the method of proof, but one conceptual error is made.

[2] Some correct relevant statements about the proof are made, but three or four statements or reasons are missing or incorrect.

[1] Only one correct statement and reason are written.

[0] The given and/or the prove statements are rewritten in the style of a formal proof, but no further correct relevant statements are written.

or

[0] A zero response is completely incorrect, irrelevant, or incoherent or is a correct response that was obtained by an obviously incorrect procedure.

Map to Core Curriculum

Content Band	Item Numbers
Geometric Relationships	4, 18, 21, 28
Constructions	25, 30
Locus	12, 32
Informal and Formal Proofs	1, 2, 6, 9, 11, 13, 14, 15, 16, 17, 24, 27, 29, 33, 34, 35, 38
Transformational Geometry	3, 5, 8, 37
Coordinate Geometry	7, 10, 19, 20, 22, 23, 26, 31, 36

Regents Examination in Geometry

June 2009

Chart for Converting Total Test Raw Scores to Final Examination Scores (Scaled Scores)

The Chart for Determining the Final Examination Score for the June 2009 Regents Examination in Geometry will be posted on the Department’s web site <http://www.emsc.nysed.gov/osa/> on Thursday, June 25, 2009.

Online Submission of Teacher Evaluations of the Test to the Department

Suggestions and feedback from teachers provide an important contribution to the test development process. The Department provides an online evaluation form for State assessments. It contains spaces for teachers to respond to several specific questions and to make suggestions. Instructions for completing the evaluation form are as follows:

1. Go to www.emsc.nysed.gov/osa/exameval.
2. Select the test title.
3. Complete the required demographic fields.
4. Complete each evaluation question and provide comments in the space provided.
5. Click the SUBMIT button at the bottom of the page to submit the completed form.



Regents Examination in Geometry June 2009

Chart for Converting Total Test Raw Scores to
Final Examination Scores (Scale Scores)

Raw Score	Scale Score	Raw Score	Scale Score	Raw Score	Scale Score	Raw Score	Scale Score
86	100	64	80	42	66	20	42
85	99	63	79	41	65	19	41
84	98	62	79	40	64	18	39
83	96	61	78	39	63	17	37
82	95	60	77	38	63	16	36
81	94	59	77	37	62	15	34
80	93	58	76	36	61	14	32
79	92	57	76	35	60	13	30
78	91	56	75	34	59	12	28
77	90	55	74	33	58	11	26
76	89	54	74	32	57	10	24
75	88	53	73	31	56	9	22
74	87	52	72	30	55	8	20
73	87	51	72	29	54	7	18
72	86	50	71	28	53	6	15
71	85	49	71	27	52	5	13
70	84	48	70	26	50	4	11
69	83	47	69	25	49	3	8
68	83	46	69	24	48	2	5
67	82	45	68	23	47	1	3
66	81	44	67	22	45	0	0
65	81	43	66	21	44		

To determine the student's final examination score, find the student's total test raw score in the column labeled "Raw Score" and then locate the scale score that corresponds to that raw score. The scale score is the student's final examination score. Enter this score in the space labeled "Scale Score" on the student's answer sheet.

It is recommended that all student answer papers that receive a scale score of 60 through 64 be scored a second time to ensure the accuracy of the score. For the second scoring, a different committee of teachers may score the student's paper or the original committee may score the paper, except that no teacher may score the same open-ended questions that he/she scored in the first rating of the paper.

Because scale scores corresponding to raw scores in the conversion chart change from one examination to another, it is crucial that for each administration, the conversion chart provided for that administration be used to determine the student's final score. The chart above is usable only for this administration of the Regents Examination in Geometry.