

0609ge

- 1 Juliann plans on drawing  $\triangle ABC$ , where the measure of  $\angle A$  can range from  $50^\circ$  to  $60^\circ$  and the measure of  $\angle B$  can range from  $90^\circ$  to  $100^\circ$ . Given these conditions, what is the correct range of measures possible for  $\angle C$ ?
- 1)  $20^\circ$  to  $40^\circ$
  - 2)  $30^\circ$  to  $50^\circ$
  - 3)  $80^\circ$  to  $90^\circ$
  - 4)  $120^\circ$  to  $130^\circ$

- 2 In the diagram of  $\triangle ABC$  and  $\triangle DEF$  below,  $\overline{AB} \cong \overline{DE}$ ,  $\angle A \cong \angle D$ , and  $\angle B \cong \angle E$ .

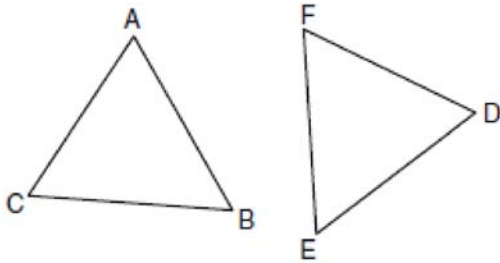

Which method can be used to prove  $\triangle ABC \cong \triangle DEF$ ?

- 1) SSS
- 2) SAS
- 3) ASA
- 4) HL

- 3 In the diagram below, under which transformation will  $\triangle A'B'C'$  be the image of  $\triangle ABC$ ?

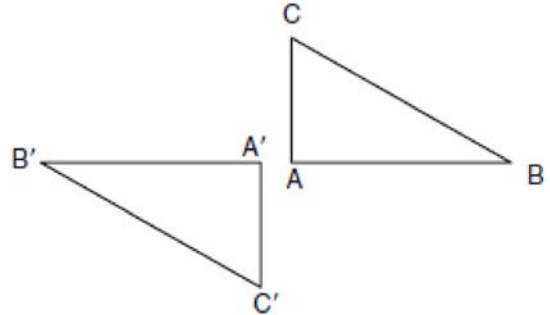

- 1) rotation
  - 2) dilation
  - 3) translation
  - 4) glide reflection
- 4 The lateral faces of a regular pyramid are composed of
- 1) squares
  - 2) rectangles
  - 3) congruent right triangles
  - 4) congruent isosceles triangles
- 5 Point  $A$  is located at  $(4, -7)$ . The point is reflected in the  $x$ -axis. Its image is located at
- 1)  $(-4, 7)$
  - 2)  $(-4, -7)$
  - 3)  $(4, 7)$
  - 4)  $(7, -4)$

- 6 In the diagram of circle  $O$  below, chords  $\overline{AB}$  and  $\overline{CD}$  are parallel, and  $\overline{BD}$  is a diameter of the circle.

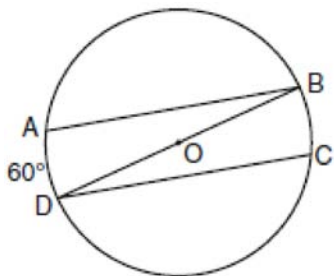

If  $m\widehat{AD} = 60$ , what is  $m\angle CDB$ ?

- 1) 20
  - 2) 30
  - 3) 60
  - 4) 120
- 7 What is an equation of the line that passes through the point  $(-2, 5)$  and is perpendicular to the line whose equation is  $y = \frac{1}{2}x + 5$ ?
- 1)  $y = 2x + 1$
  - 2)  $y = -2x + 1$
  - 3)  $y = 2x + 9$
  - 4)  $y = -2x - 9$

- 8 After a composition of transformations, the coordinates  $A(4, 2)$ ,  $B(4, 6)$ , and  $C(2, 6)$  become  $A''(-2, -1)$ ,  $B''(-2, -3)$ , and  $C''(-1, -3)$ , as shown on the set of axes below.

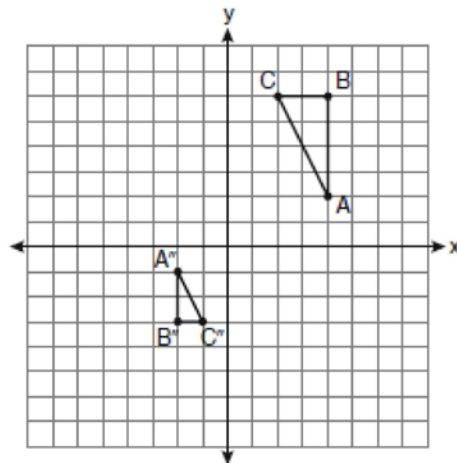

Which composition of transformations was used?

- 1)  $R_{180^\circ} \circ D_2$
  - 2)  $R_{90^\circ} \circ D_2$
  - 3)  $D_{\frac{1}{2}} \circ R_{180^\circ}$
  - 4)  $D_{\frac{1}{2}} \circ R_{90^\circ}$
- 9 In an equilateral triangle, what is the difference between the sum of the exterior angles and the sum of the interior angles?
- 1)  $180^\circ$
  - 2)  $120^\circ$
  - 3)  $90^\circ$
  - 4)  $60^\circ$

10 What is an equation of a circle with its center at  $(-3, 5)$  and a radius of 4?

- 1)  $(x - 3)^2 + (y + 5)^2 = 16$
- 2)  $(x + 3)^2 + (y - 5)^2 = 16$
- 3)  $(x - 3)^2 + (y + 5)^2 = 4$
- 4)  $(x + 3)^2 + (y - 5)^2 = 4$

11 In  $\triangle ABC$ ,  $m\angle A = 95$ ,  $m\angle B = 50$ , and  $m\angle C = 35$ . Which expression correctly relates the lengths of the sides of this triangle?

- 1)  $AB < BC < CA$
- 2)  $AB < AC < BC$
- 3)  $AC < BC < AB$
- 4)  $BC < AC < AB$

12 In a coordinate plane, how many points are both 5 units from the origin and 2 units from the  $x$ -axis?

- 1) 1
- 2) 2
- 3) 3
- 4) 4

13 What is the contrapositive of the statement, "If I am tall, then I will bump my head"?

- 1) If I bump my head, then I am tall.
- 2) If I do not bump my head, then I am tall.
- 3) If I am tall, then I will not bump my head.
- 4) If I do not bump my head, then I am not tall.

14 In the diagram of  $\triangle ABC$  below, Jose found centroid  $P$  by constructing the three medians. He measured  $\overline{CF}$  and found it to be 6 inches.

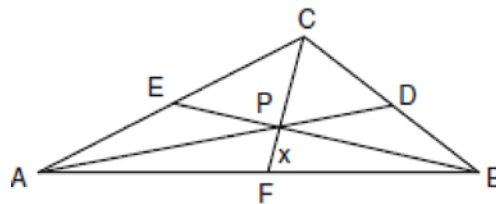

If  $PF = x$ , which equation can be used to find  $x$ ?

- 1)  $x + x = 6$
- 2)  $2x + x = 6$
- 3)  $3x + 2x = 6$
- 4)  $x + \frac{2}{3}x = 6$

15 In the diagram below, the length of the legs  $\overline{AC}$  and  $\overline{BC}$  of right triangle  $ABC$  are 6 cm and 8 cm, respectively. Altitude  $\overline{CD}$  is drawn to the hypotenuse of  $\triangle ABC$ .

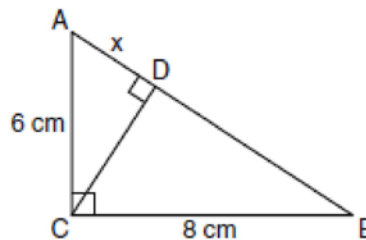

What is the length of  $\overline{AD}$  to the nearest tenth of a centimeter?

- 1) 3.6
- 2) 6.0
- 3) 6.4
- 4) 4.0

- 16 In the diagram below, tangent  $\overline{AB}$  and secant  $\overline{ACD}$  are drawn to circle  $O$  from an external point  $A$ ,  $AB = 8$ , and  $AC = 4$ .

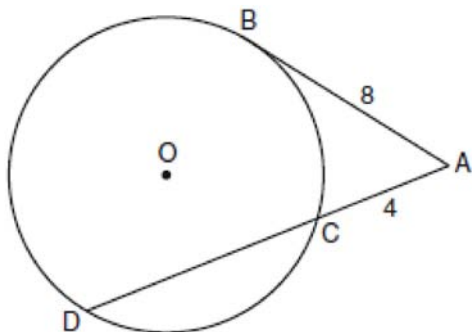

What is the length of  $\overline{CD}$ ?

- 1) 16
  - 2) 13
  - 3) 12
  - 4) 10
- 17 In the diagram of  $\triangle ABC$  and  $\triangle EDC$  below,  $\overline{AE}$  and  $\overline{BD}$  intersect at  $C$ , and  $\angle CAB \cong \angle CED$ .

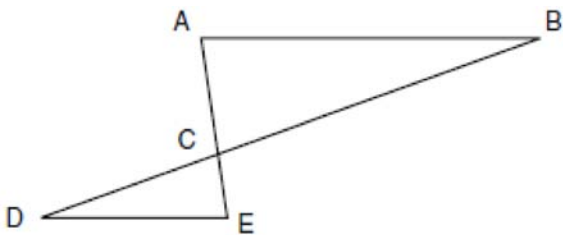

Which method can be used to show that  $\triangle ABC$  must be similar to  $\triangle EDC$ ?

- 1) SAS
- 2) AA
- 3) SSS
- 4) HL

- 18 Point  $P$  is on line  $m$ . What is the total number of planes that are perpendicular to line  $m$  and pass through point  $P$ ?

- 1) 1
- 2) 2
- 3) 0
- 4) infinite

- 19 Square  $LMNO$  is shown in the diagram below.

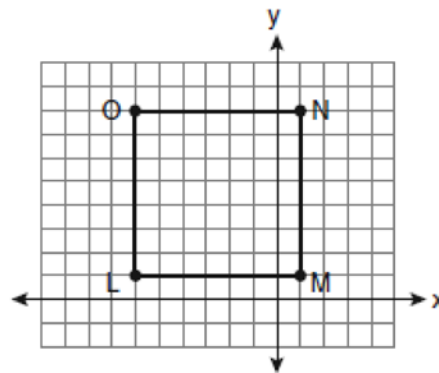

What are the coordinates of the midpoint of diagonal  $\overline{LN}$ ?

- 1)  $\left(4\frac{1}{2}, -2\frac{1}{2}\right)$
- 2)  $\left(-3\frac{1}{2}, 3\frac{1}{2}\right)$
- 3)  $\left(-2\frac{1}{2}, 3\frac{1}{2}\right)$
- 4)  $\left(-2\frac{1}{2}, 4\frac{1}{2}\right)$

- 20 Which graph represents a circle with the equation  $(x-5)^2 + (y+1)^2 = 9$ ?

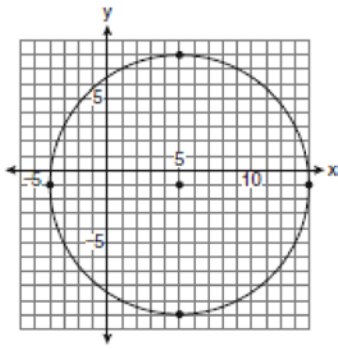
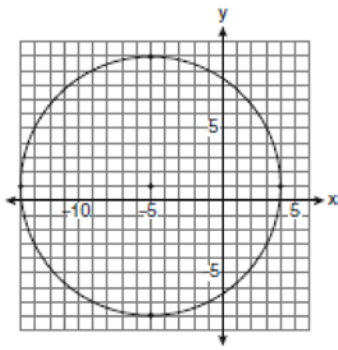
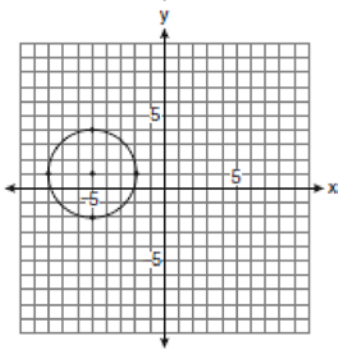
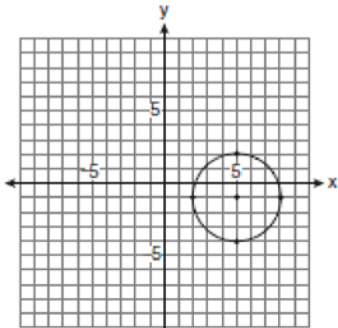

- 21 In the diagram below, a right circular cone has a diameter of 8 inches and a height of 12 inches.

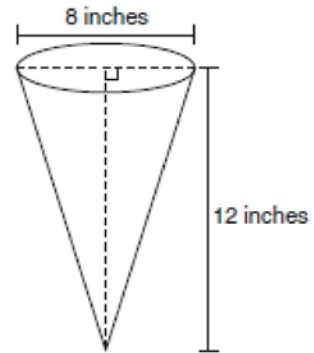

What is the volume of the cone to the *nearest cubic inch*?

- 1) 201  
 2) 481  
 3) 603  
 4) 804
- 22 A circle is represented by the equation  $x^2 + (y+3)^2 = 13$ . What are the coordinates of the center of the circle and the length of the radius?
- 1) (0,3) and 13  
 2) (0,3) and  $\sqrt{13}$   
 3) (0,-3) and 13  
 4) (0,-3) and  $\sqrt{13}$

- 23 Given the system of equations:

$$y = x^2 - 4x$$

$$x = 4$$

The number of points of intersection is

- 1) 1  
 2) 2  
 3) 3  
 4) 0

- 24 Side  $\overline{PQ}$  of  $\triangle PQR$  is extended through  $Q$  to point  $T$ . Which statement is *not* always true?
- 1)  $m\angle RQT > m\angle R$
  - 2)  $m\angle RQT > m\angle P$
  - 3)  $m\angle RQT = m\angle P + m\angle R$
  - 4)  $m\angle RQT > m\angle PQR$

- 25 Which illustration shows the correct construction of an angle bisector?

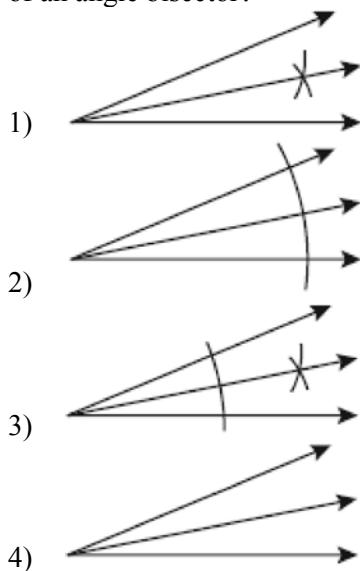

- 26 Which equation represents a line perpendicular to the line whose equation is  $2x + 3y = 12$ ?
- 1)  $6y = -4x + 12$
  - 2)  $2y = 3x + 6$
  - 3)  $2y = -3x + 6$
  - 4)  $3y = -2x + 12$

- 27 In  $\triangle ABC$ , point  $D$  is on  $\overline{AB}$ , and point  $E$  is on  $\overline{BC}$  such that  $\overline{DE} \parallel \overline{AC}$ . If  $DB = 2$ ,  $DA = 7$ , and  $DE = 3$ , what is the length of  $\overline{AC}$ ?
- 1) 8
  - 2) 9
  - 3) 10.5
  - 4) 13.5

- 28 In three-dimensional space, two planes are parallel and a third plane intersects both of the parallel planes. The intersection of the planes is a
- 1) plane
  - 2) point
  - 3) pair of parallel lines
  - 4) pair of intersecting lines

- 29 In the diagram of  $\triangle ABC$  below,  $AB = 10$ ,  $BC = 14$ , and  $AC = 16$ . Find the perimeter of the triangle formed by connecting the midpoints of the sides of  $\triangle ABC$ .

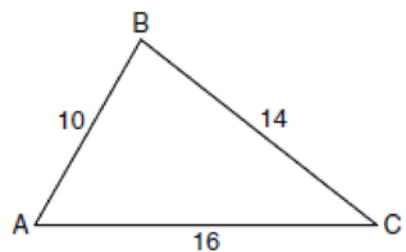

- 30 Using a compass and straightedge, construct a line that passes through point  $P$  and is perpendicular to line  $m$ . [Leave all construction marks.]

•  $P$



- 31 Find an equation of the line passing through the point  $(5, 4)$  and parallel to the line whose equation is  $2x + y = 3$ .

- 32 The length of  $\overline{AB}$  is 3 inches. On the diagram below, sketch the points that are equidistant from  $A$  and  $B$  and sketch the points that are 2 inches from  $A$ . Label with an **X** all points that satisfy both conditions.



- 33 Given: Two is an even integer or three is an even integer.  
Determine the truth value of this disjunction.  
Justify your answer.

- 36 Triangle  $ABC$  has coordinates  $A(-6,2)$ ,  $B(-3,6)$ , and  $C(5,0)$ . Find the perimeter of the triangle.  
Express your answer in simplest radical form. [The use of the grid below is optional.]

- 34 In the diagram below,  $\triangle ABC \sim \triangle EFG$ ,  $m\angle C = 4x + 30$ , and  $m\angle G = 5x + 10$ . Determine the value of  $x$ .

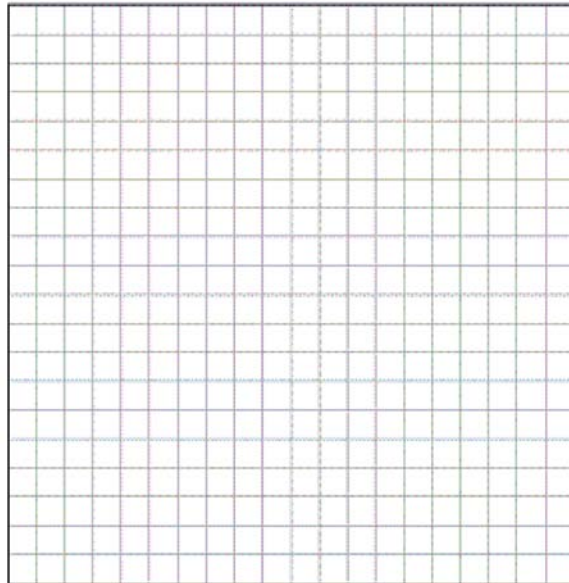
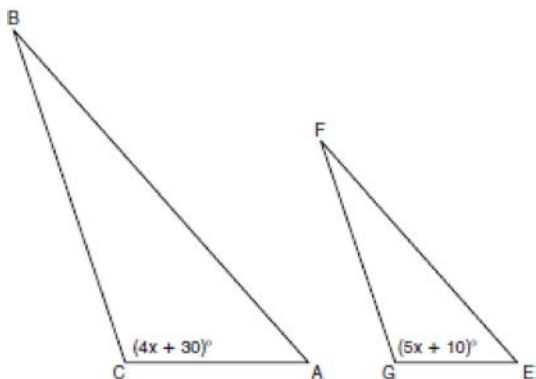

- 35 In the diagram below, circles  $X$  and  $Y$  have two tangents drawn to them from external point  $T$ . The points of tangency are  $C$ ,  $A$ ,  $S$ , and  $E$ . The ratio of  $\overline{TA}$  to  $\overline{AC}$  is  $1:3$ . If  $TS = 24$ , find the length of  $\overline{SE}$ .

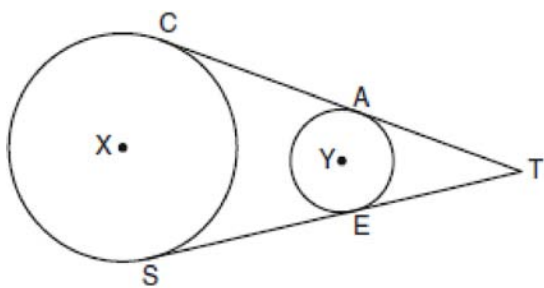

(Not drawn to scale)

- 37 The coordinates of the vertices of parallelogram  $ABCD$  are  $A(-2,2)$ ,  $B(3,5)$ ,  $C(4,2)$ , and  $D(-1,-1)$ . State the coordinates of the vertices of parallelogram  $A''B''C''D''$  that result from the transformation  $r_{y\text{-axis}} \circ T_{2,-3}$ . [The use of the set of axes below is optional. ]

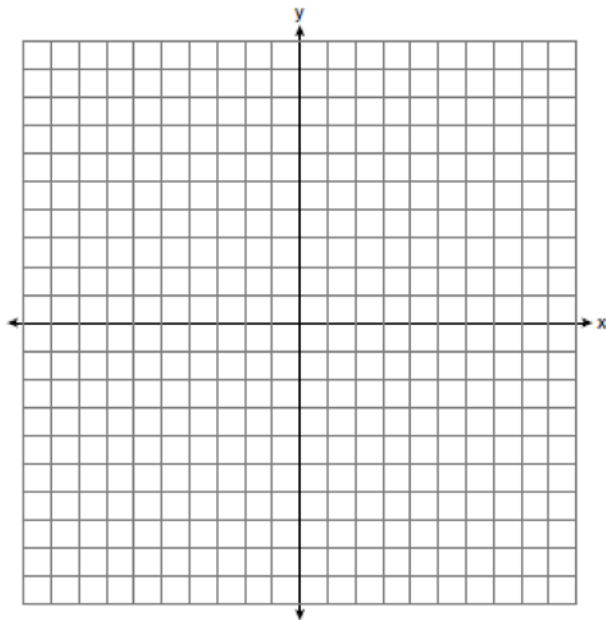

- 38 Given:  $\triangle ABC$  and  $\triangle EDC$ ,  $C$  is the midpoint of  $\overline{BD}$  and  $\overline{AE}$   
 Prove:  $\overline{AB} \parallel \overline{DE}$

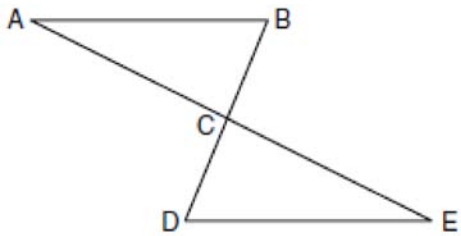

**0609ge**  
**Answer Section**

1	ANS: 1	PTS: 2	REF: 060901ge	STA: G.G.30
	TOP: Interior and Exterior Angles of Triangles			
2	ANS: 3	PTS: 2	REF: 060902ge	STA: G.G.28
	TOP: Congruency Proofs			
3	ANS: 1	PTS: 2	REF: 060903ge	STA: G.G.56
	TOP: Identifying Transformations			
4	ANS: 4	PTS: 2	REF: 060904ge	STA: G.G.13
	TOP: Classifying Solids			
5	ANS: 3	PTS: 2	REF: 060905ge	STA: G.G.54
	TOP: Reflections			
6	ANS: 2	PTS: 2	REF: 060906ge	STA: G.G.52
	TOP: Chords			
7	ANS: 2	PTS: 2	REF: 060907ge	STA: G.G.64
	TOP: Parallel and Perpendicular Lines			
8	ANS: 3	PTS: 2	REF: 060908ge	STA: G.G.60
	TOP: Compositions of Transformations			
9	ANS: 1	PTS: 2	REF: 060909ge	STA: G.G.30
	TOP: Interior and Exterior Angles of Triangles			
10	ANS: 2	PTS: 2	REF: 060910ge	STA: G.G.71
	TOP: Writing Equations of Circles			
11	ANS: 2	PTS: 2	REF: 060911ge	STA: G.G.34
	TOP: Interior and Exterior Angles of Triangles			
12	ANS: 4	PTS: 2	REF: 060912ge	STA: G.G.22
	TOP: Locus-2			
13	ANS: 4	PTS: 2	REF: 060913ge	STA: G.G.26
	TOP: Contrapositive			
14	ANS: 2	PTS: 2	REF: 060914ge	STA: G.G.43
	TOP: Medians, Altitudes, Bisectors and Midsegments			
15	ANS: 1	PTS: 2	REF: 060915ge	STA: G.G.47
	TOP: Similarity			
16	ANS: 3	PTS: 2	REF: 060916ge	STA: G.G.53
	TOP: Chords, Secants and Tangents			
17	ANS: 2	PTS: 2	REF: 060917ge	STA: G.G.44
	TOP: Similarity Proofs			
18	ANS: 1	PTS: 2	REF: 060918ge	STA: G.G.2
	TOP: Planes			
19	ANS: 4	PTS: 2	REF: 060919ge	STA: G.G.66
	TOP: Midpoint			
20	ANS: 1	PTS: 2	REF: 060920ge	STA: G.G.74
	TOP: Graphing Circles			
21	ANS: 1	PTS: 2	REF: 060921ge	STA: G.G.15
	TOP: Volume			
22	ANS: 4	PTS: 2	REF: 060922ge	STA: G.G.73
	TOP: Finding the Center and Radius of Circles			

- 23 ANS: 1            PTS: 2            REF: 060923ge        STA: G.G.70  
TOP: Quadratic-Linear Systems
- 24 ANS: 4            PTS: 2            REF: 060924ge        STA: G.G.33  
TOP: Triangle Inequalities
- 25 ANS: 3            PTS: 2            REF: 060925ge        STA: G.G.17  
TOP: Constructions
- 26 ANS: 2            PTS: 2            REF: 060926ge        STA: G.G.63  
TOP: Parallel and Perpendicular Lines
- 27 ANS: 4            PTS: 2            REF: 060927ge        STA: G.G.45  
TOP: Similarity
- 28 ANS: 3            PTS: 2            REF: 060928ge        STA: G.G.8  
TOP: Planes
- 29 ANS:  
20

PTS: 2            REF: 060929ge        STA: G.G.42  
TOP: Medians, Altitudes, Bisectors and Midsegments

30 ANS:

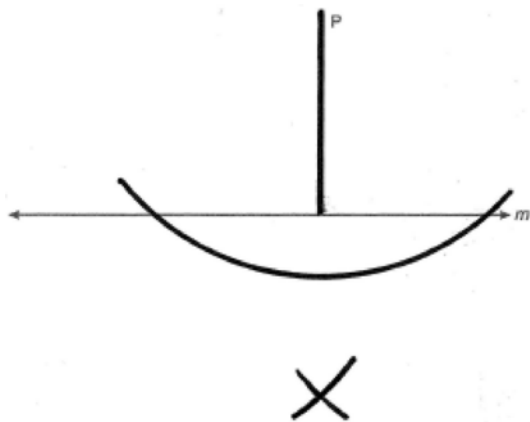

- PTS: 2            REF: 060930ge        STA: G.G.19            TOP: Constructions
- 31 ANS:  
 $y = -2x + 14$

PTS: 2            REF: 060931ge        STA: G.G.65            TOP: Parallel and Perpendicular Lines

32 ANS:

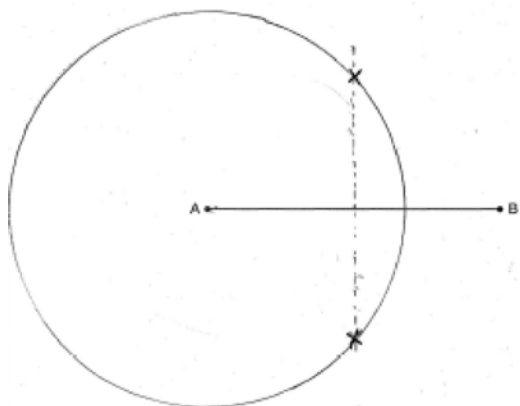

PTS: 2 REF: 060932ge STA: G.G.22 TOP: Locus-2

33 ANS:

True. The first statement is true and the second statement is false. In a disjunction, if either statement is true, the disjunction is true.

PTS: 2 REF: 060933ge STA: G.G.25 TOP: Logical Reasoning

34 ANS:

20

PTS: 2 REF: 060934ge STA: G.G.45 TOP: Similarity

35 ANS:

18

PTS: 4 REF: 060935ge STA: G.G.50 TOP: Tangents

36 ANS:

$15 + 5\sqrt{5}$

PTS: 4 REF: 060936ge STA: G.G.69 TOP: Perimeter

37 ANS:

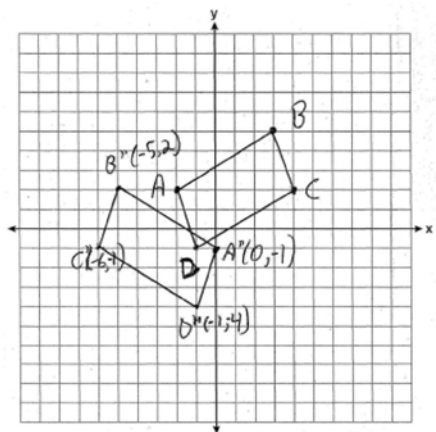

PTS: 4 REF: 060937ge STA: G.G.58 TOP: Compositions of Transformations

38 ANS:  $\overline{AC} \cong \overline{EC}$  and  $\overline{DC} \cong \overline{BC}$  because of the definition of midpoint.  $\angle ACB \cong \angle ECD$  because of vertical angles.  $\triangle ABC \cong \triangle EDC$  because of SAS.  $\angle CDE \cong \angle CBA$  because of CPCTC.  $\overline{BD}$  is a transversal intersecting  $\overline{AB}$  and  $\overline{ED}$ . Therefore  $\overline{AB} \parallel \overline{DE}$  because  $\angle CDE$  and  $\angle CBA$  are congruent alternate interior angles.

PTS: 6

REF: 060938ge

STA: G.G.27

TOP: Congruency Proofs