

1. 060901ge, P.I. G.G.30
Juliann plans on drawing $\triangle ABC$, where the measure of $\angle A$ can range from 50° to 60° and the measure of $\angle B$ can range from 90° to 100° . Given these conditions, what is the correct range of measures possible for $\angle C$?
- [A] 120° to 130° [B] 30° to 50°
[C] 20° to 40° [D] 80° to 90°

2. 060902ge, P.I. G.G.28
In the diagram of $\triangle ABC$ and $\triangle DEF$ below, $\overline{AB} \cong \overline{DE}$, $\angle A \cong \angle D$, and $\angle B \cong \angle E$.

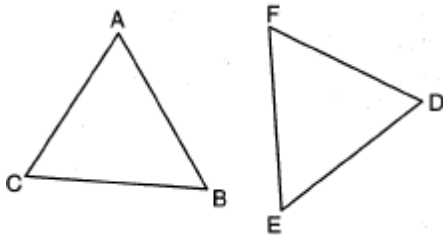

Which method can be used to prove $\triangle ABC \cong \triangle DEF$?

- [A] ASA [B] HL [C] SAS [D] SSS
3. 060903ge, P.I. G.G.56
In the diagram below, under which transformation will $\triangle A'B'C'$ be the image of $\triangle ABC$?

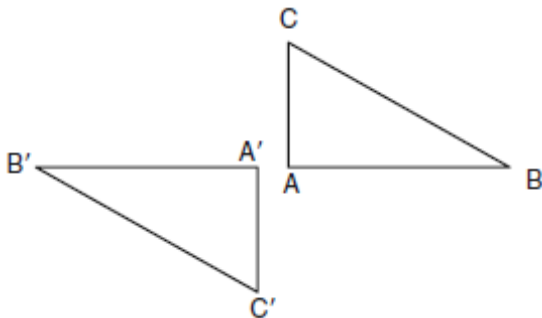

- [A] translation [B] rotation
[C] glide reflection [D] dilation

4. 060904ge, P.I. G.G.13
The lateral faces of a regular pyramid are composed of
- [A] congruent right triangles
[B] congruent isosceles triangles
[C] rectangles [D] squares

5. 060905ge, P.I. G.G.54
Point A is located at $(4,-7)$. The point is reflected in the x -axis. Its image is located at
- [A] $(7,-4)$ [B] $(4,7)$
[C] $(-4,7)$ [D] $(-4,-7)$

6. 060906ge, P.I. G.G.52
In the diagram of circle O below, chords \overline{AB} and \overline{CD} are parallel, and \overline{BD} is a diameter of the circle.

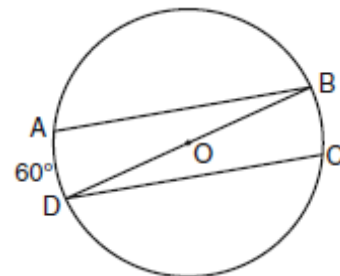

If $m\widehat{AD} = 60$, what is $m\angle CDB$?

- [A] 120 [B] 30 [C] 60 [D] 20
7. 060907ge, P.I. G.G.64
What is an equation of the line that passes through the point $(-2,5)$ and is perpendicular to the line whose equation is $y = \frac{1}{2}x + 5$?
- [A] $y = 2x + 9$ [B] $y = -2x + 1$
[C] $y = -2x - 9$ [D] $y = 2x + 1$

8. 060908ge, P.I. G.G.60
After a composition of transformations, the coordinates $A(4,2)$, $B(4,6)$, and $C(2,6)$ become $A''(-2,-1)$, $B''(-2,-3)$, and $C''(-1,-3)$, as shown on the set of axes below.

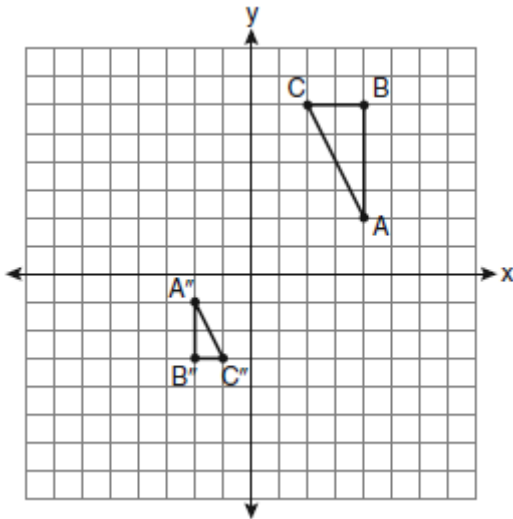

Which composition of transformations was used?

- [A] $D_{\frac{1}{2}} \circ R_{90^\circ}$ [B] $R_{180^\circ} \circ D_2$
[C] $D_{\frac{1}{2}} \circ R_{180^\circ}$ [D] $R_{90^\circ} \circ D_2$
9. 060909ge, P.I. G.G.30
In an equilateral triangle, what is the difference between the sum of the exterior angles and the sum of the interior angles?
[A] 90° [B] 120° [C] 180° [D] 60°
10. 060910ge, P.I. G.G.71
What is an equation of a circle with its center at $(-3,5)$ and a radius of 4?
[A] $(x+3)^2 + (y-5)^2 = 16$
[B] $(x-3)^2 + (y+5)^2 = 16$
[C] $(x-3)^2 + (y+5)^2 = 4$
[D] $(x+3)^2 + (y-5)^2 = 4$

11. 060911ge, P.I. G.G.34
In $\triangle ABC$, $m\angle A = 95$, $m\angle B = 50$, and $m\angle C = 35$. Which expression correctly relates the lengths of the sides of this triangle?
[A] $AC < BC < AB$ [B] $BC < AC < AB$
[C] $AB < BC < CA$ [D] $AB < AC < BC$
12. 060912ge, P.I. G.G.22
In a coordinate plane, how many points are both 5 units from the origin and 2 units from the x -axis?
[A] 1 [B] 2 [C] 3 [D] 4
13. 060913ge, P.I. G.G.26
What is the contrapositive of the statement, "If I am tall, then I will bump my head"?
[A] If I do not bump my head, then I am not tall.
[B] If I do not bump my head, then I am tall.
[C] If I am tall, then I will not bump my head.
[D] If I bump my head, then I am tall.
14. 060914ge, P.I. G.G.43
In the diagram of $\triangle ABC$ below, Jose found centroid P by constructing the three medians. He measured \overline{CF} and found it to be 6 inches.

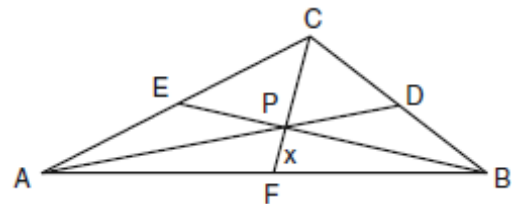

If $PF = x$, which equation can be used to find x ?

- [A] $2x + x = 6$ [B] $3x + 2x = 6$
[C] $x + x = 6$ [D] $x + \frac{2}{3}x = 6$

15. 060915ge, P.I. G.G.47

In the diagram below, the length of the legs \overline{AC} and \overline{BC} of right triangle ABC are 6 cm and 8 cm, respectively. Altitude \overline{CD} is drawn to the hypotenuse of $\triangle ABC$.

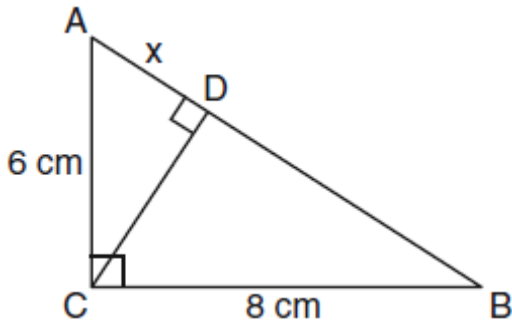

What is the length of \overline{AD} to the nearest tenth of a centimeter?

- [A] 3.6 [B] 4.0 [C] 6.4 [D] 6.0

16. 060916ge, P.I. G.G.53

In the diagram below, tangent \overline{AB} and secant \overline{ACD} are drawn to circle O from an external point A , $AB = 8$, and $AC = 4$.

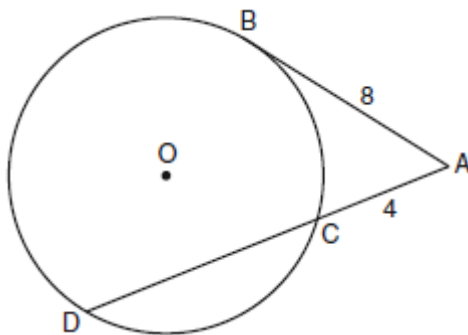

What is the length of \overline{CD} ?

- [A] 16 [B] 12 [C] 13 [D] 10

17. 060917ge, P.I. G.G.44

In the diagram of $\triangle ABC$ and $\triangle EDC$ below, \overline{AE} and \overline{BD} intersect at C , and $\angle CAB \cong \angle CED$.

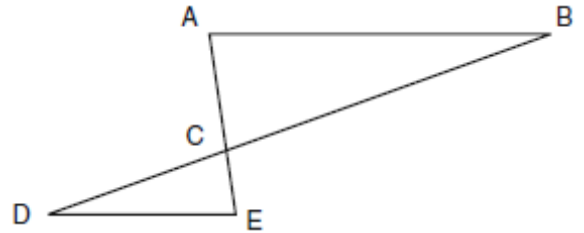

Which method can be used to show that $\triangle ABC$ must be similar to $\triangle EDC$?

- [A] HL [B] SSS [C] AA [D] SAS

18. 060918ge, P.I. G.G.2

Point P is on line m . What is the total number of planes that are perpendicular to line m and pass through point P ?

- [A] 2 [B] infinite [C] 0 [D] 1

19. 060919ge, P.I. G.G.66

Square $LMNO$ is shown in the diagram below.

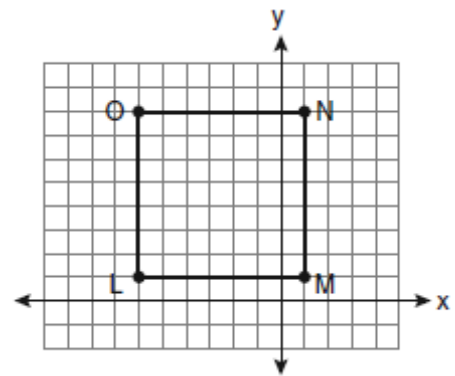

What are the coordinates of the midpoint of diagonal \overline{LN} ?

- [A] $(4\frac{1}{2}, -2\frac{1}{2})$ [B] $(-3\frac{1}{2}, 3\frac{1}{2})$

- [C] $(-2\frac{1}{2}, 4\frac{1}{2})$ [D] $(-2\frac{1}{2}, 3\frac{1}{2})$

20. 060920ge, P.I. G.G.74

Which graph represents a circle with the equation $(x - 5)^2 + (y + 1)^2 = 9$?

[A]

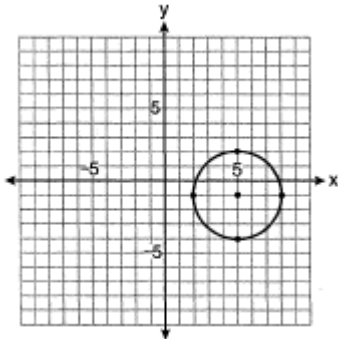

[B]

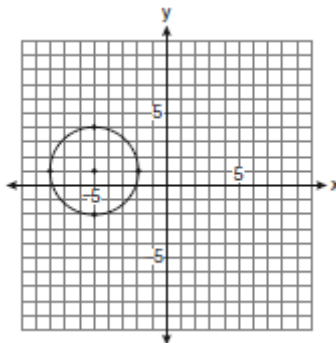

[C]

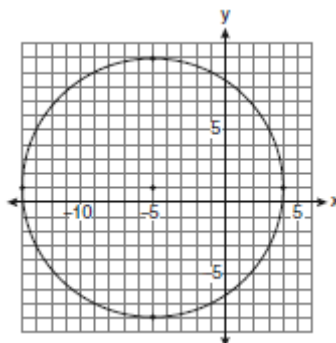

[D]

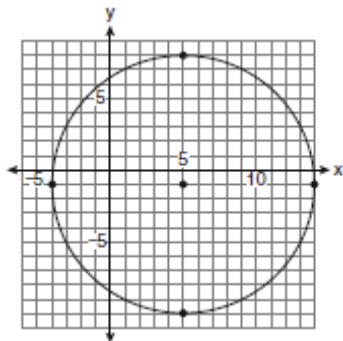

21. 060921ge, P.I. G.G.15

In the diagram below, a right circular cone has a diameter of 8 inches and a height of 12 inches.

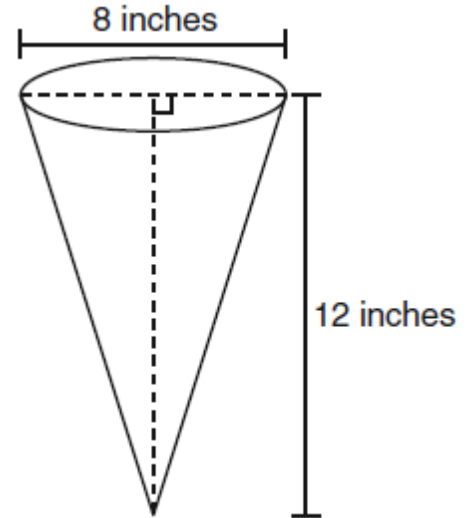

What is the volume of the cone to the *nearest cubic inch*?

- [A] 603 [B] 804 [C] 201 [D] 481

22. 060922ge, P.I. G.G.73

A circle is represented by the equation $x^2 + (y + 3)^2 = 13$. What are the coordinates of the center of the circle and the length of the radius?

- [A] (0,3) and $\sqrt{13}$ [B] (0,-3) and 13
[C] (0,3) and 13 [D] (0,-3) and $\sqrt{13}$

23. 060923ge, P.I. G.G.70

Given the system of equations:
 $y = x^2 - 4x$
 $x = 4$

The number of points of intersection is

- [A] 3 [B] 1 [C] 2 [D] 0

24. 060924ge, P.I. G.G.33

Side \overline{PQ} of $\triangle PQR$ is extended through Q to point T . Which statement is *not* always true?

- [A] $m\angle RQT = m\angle P + m\angle R$
- [B] $m\angle RQT > m\angle P$
- [C] $m\angle RQT > m\angle PQR$
- [D] $m\angle RQT > m\angle R$

25. 060925ge, P.I. G.G.17

Which illustration shows the correct construction of an angle bisector?

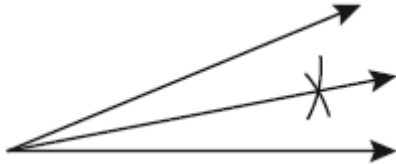
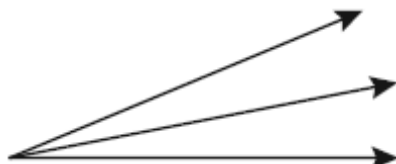
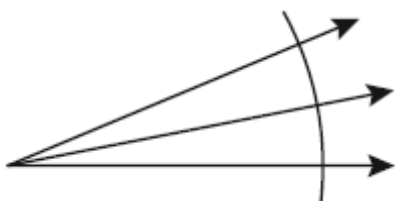
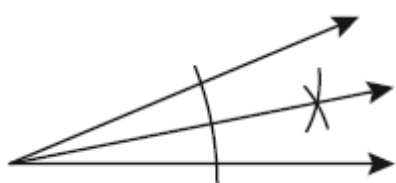
- [A] 
- [B] 
- [C] 
- [D] 

26. 060926ge, P.I. G.G.63

Which equation represents a line perpendicular to the line whose equation is $2x + 3y = 12$?

- [A] $2y = -3x + 6$
- [B] $6y = -4x + 12$
- [C] $2y = 3x + 6$
- [D] $3y = -2x + 12$

27. 060927ge, P.I. G.G.45

In $\triangle ABC$, point D is on \overline{AB} , and point E is on \overline{BC} such that $\overline{DE} \parallel \overline{AC}$. If $DB = 2$, $DA = 7$, and $DE = 3$, what is the length of \overline{AC} ?

- [A] 13.5
- [B] 10.5
- [C] 9
- [D] 8

28. 060928ge, P.I. G.G.8

In three-dimensional space, two planes are parallel and a third plane intersects both of the parallel planes. The intersection of the planes is a

- [A] point
- [B] pair of parallel lines
- [C] plane
- [D] pair of intersecting lines

29. 060929ge, P.I. G.G.42

In the diagram of $\triangle ABC$ below, $AB = 10$, $BC = 14$, and $AC = 16$. Find the perimeter of the triangle formed by connecting the midpoints of the sides of $\triangle ABC$.

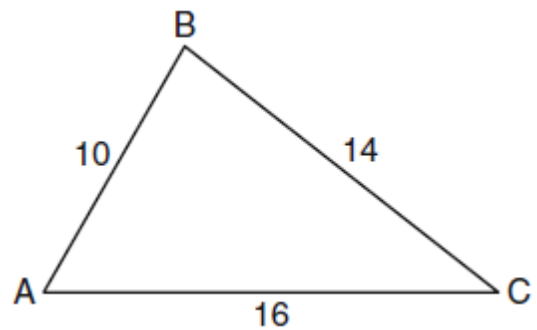

30. 060930ge, P.I. G.G.19
Using a compass and straightedge, construct a line that passes through point P and is perpendicular to line m . [Leave all construction marks.]

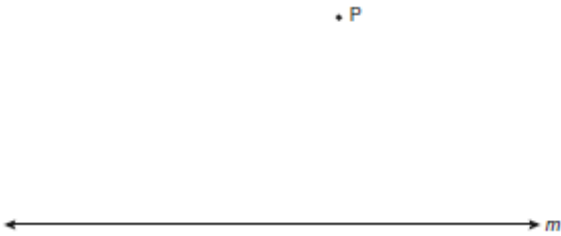

31. 060931ge, P.I. G.G.65
Find an equation of the line passing through the point $(5,4)$ and parallel to the line whose equation is $2x + y = 3$.

32. 060932ge, P.I. G.G.22
The length of \overline{AB} is 3 inches. On the diagram below, sketch the points that are equidistant from A and B and sketch the points that are 2 inches from A . Label with an **X** all points that satisfy both conditions.



33. 060933ge, P.I. G.G.25
Given: Two is an even integer or three is an even integer.
Determine the truth value of this disjunction.
Justify your answer.
34. 060934ge, P.I. G.G.45
In the diagram below, $\triangle ABC \sim \triangle EFG$,
 $m\angle C = 4x + 30$, and $m\angle G = 5x + 10$.
Determine the value of x .

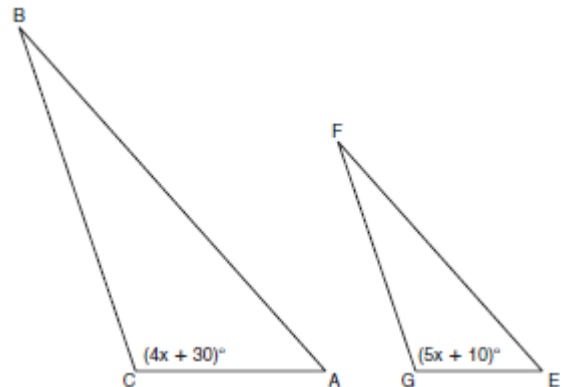

35. 060935ge, P.I. G.G.50

In the diagram below, circles X and Y have two tangents drawn to them from external point T . The points of tangency are C , A , S , and E . The ratio of TA to AC is $1:3$. If $TS = 24$, find the length of \overline{SE} .

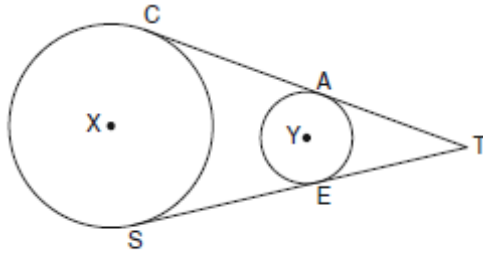

(Not drawn to scale)

36. 060936ge, P.I. G.G.69

Triangle ABC has coordinates $A(-6,2)$, $B(-3,6)$, and $C(5,0)$. Find the perimeter of the triangle. Express your answer in simplest radical form. [The use of the grid below is optional.]

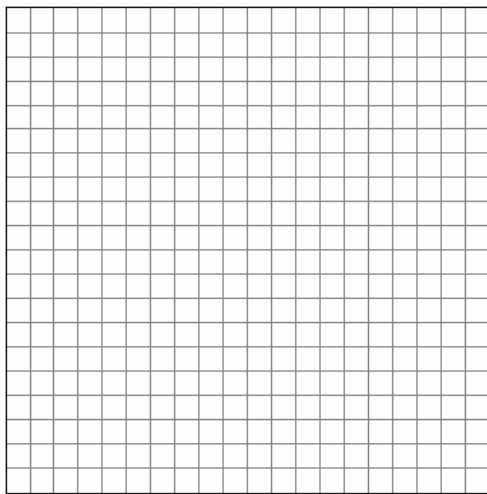

37. 060937ge, P.I. G.G.58

The coordinates of the vertices of parallelogram $ABCD$ are $A(-2,2)$, $B(3,5)$, $C(4,2)$, and $D(-1,-1)$. State the coordinates of the vertices of parallelogram $A''B''C''D''$ that result from the transformation $r_{y\text{-axis}} \circ T_{2,-3}$. [The use of the set of axes below is optional.]

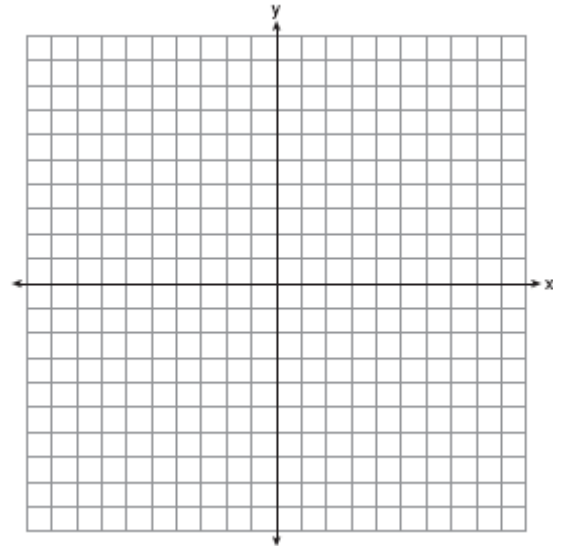

38. 060938ge, P.I. G.G.27

Given: $\triangle ABC$ and $\triangle EDC$, C is the midpoint of \overline{BD} and \overline{AE}
Prove: $\overline{AB} \parallel \overline{DE}$

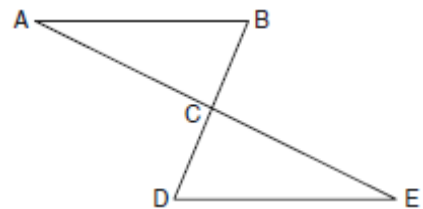

- [1] C _____
- [2] A _____
- [3] B _____
- [4] B _____
- [5] B _____
- [6] B _____
- [7] B _____
- [8] C _____
- [9] C _____
- [10] A _____
- [11] D _____
- [12] D _____
- [13] A _____
- [14] A _____
- [15] A _____
- [16] B _____
- [17] C _____
- [18] D _____
- [19] C _____
- [20] A _____
- [21] C _____
- [22] D _____
- [23] B _____
- [24] C _____
- [25] D _____
- [26] C _____
- [27] A _____
- [28] B _____

- [2] 20, and appropriate work is shown.
[1] Appropriate work is shown, but one computational error is made.
or [1] Appropriate work is shown, but one conceptual error is made.
or [1] 20, but no work is shown.
[0] A zero response is completely incorrect, irrelevant, or incoherent or is a correct response that was obtained by an obviously incorrect procedure.
-
- [29] [2] A correct construction is drawn showing all appropriate arcs, and the perpendicular line is drawn.
[1] Appropriate work is shown, but one construction error is made, such as not drawing the perpendicular line.
or [1] Appropriate work is shown, but one conceptual error is made.
[0] A drawing that is not an appropriate construction is shown.
or [0] A zero response is completely incorrect, irrelevant, or incoherent or is a correct response that was obtained by an obviously incorrect procedure.
-
- [30] [2] $y - 4 = -2(x - 5)$ or an equivalent equation, and appropriate work is shown.
[1] Appropriate work is shown, but one computational error is made.
or [1] Appropriate work is shown, but one conceptual error is made, such as leaving the answer as $\frac{y - 4}{x - 5} = \frac{-2}{1}$, which has a domain restriction.
or [1] $y - 4 = -2(x - 5)$ or an equivalent equation, but no work is shown.
[0] A zero response is completely incorrect, irrelevant, or incoherent or is a correct response that was obtained by an obviously incorrect procedure.
-
- [31] _____

- [2] Both loci are sketched correctly, and the two points of intersection are labeled with an **X**.
[1] Both loci are sketched correctly, but the points of intersection are not labeled or are labeled incorrectly.
or [1] Appropriate work is shown, but one conceptual error is made, but appropriate points of intersection are labeled.
[0] A zero response is completely incorrect, irrelevant, or incoherent or is a correct response that was obtained by an obviously incorrect procedure.
-
- [32] [2] True, and an appropriate justification is written.
[1] True, but the justification is incorrect.
or [1] One conceptual error is made in evaluating the disjunction, but an appropriate justification is written.
[0] True, but no justification is written.
or [0] A zero response is completely incorrect, irrelevant, or incoherent or is a correct response that was obtained by an obviously incorrect procedure.
-
- [33] [2] 20, and appropriate work is shown.
[1] Appropriate work is shown, but one computational error is made.
or [1] Appropriate work is shown, but one conceptual error is made.
or [1] 20, but no work is shown.
[0] A zero response is completely incorrect, irrelevant, or incoherent or is a correct response that was obtained by an obviously incorrect procedure.
-
- [34] [2] 20, and appropriate work is shown, such as $3x + x = 24$.
[3] Appropriate work is shown, but one computational error is made.
or [3] $x = 6$, and appropriate work is shown, but \overline{SE} is not found or is found incorrectly.
[2] Appropriate work is shown, but two or more computational errors are made.
or [2] Appropriate work is shown, but one conceptual error is made.
[1] Appropriate work is shown, but one conceptual error and one computational error are made.
or [1] 18, but no work is shown.
[0] A zero response is completely incorrect, irrelevant, or incoherent or is a correct response that was obtained by an obviously incorrect procedure.
-
- [35] [4] $15 + 5\sqrt{5}$, and appropriate work is shown.
[3] Appropriate work is shown, but one computational error is made.
or [3] Appropriate work is shown, but the perimeter is not expressed in simplest radical form.
or [3] Appropriate work is shown to find the length of all three sides, but the perimeter is not found.
[2] Appropriate work is shown, but two or more computational errors are made.
or [2] Appropriate work is shown, but one conceptual error is made.
or [2] Appropriate work is shown to find the lengths of two sides, but no further correct work is shown.
[1] Appropriate work is shown, but one conceptual error and one computational error are made.
or [1] Appropriate work is shown to find the length of one side, but no further correct work is shown.
or [1] $15 + 5\sqrt{5}$, but no work is shown.
[0] A zero response is completely incorrect, irrelevant, or incoherent or is a correct response that was obtained by an obviously incorrect procedure.
-
- [36] [4] 18, and appropriate work is shown, such as $3x + x = 24$.
[3] Appropriate work is shown, but one computational error is made.
or [3] $x = 6$, and appropriate work is shown, but \overline{SE} is not found or is found incorrectly.
[2] Appropriate work is shown, but two or more computational errors are made.
or [2] Appropriate work is shown, but one conceptual error is made.
[1] Appropriate work is shown, but one conceptual error and one computational error are made.
or [1] 18, but no work is shown.
[0] A zero response is completely incorrect, irrelevant, or incoherent or is a correct response that was obtained by an obviously incorrect procedure.
-

- [4] $A''(0,-1)$, $B''(-5,2)$, $C''(-6,-1)$, and $D''(-1,-4)$, and appropriate work is shown.
- [3] The composite transformation is graphed and labeled correctly, but the coordinates are not stated or are stated incorrectly.
- or [3] Appropriate work is shown, but one computational or graphing error is made.
- [2] Appropriate work is shown, but two or more computational or graphing errors are made.
- or [2] Appropriate work is shown, but one conceptual error is made, such as performing the reflection before the translation.
- [1] Appropriate work is shown, but one conceptual error and one computational or graphing error are made.
- or [1] $A''(0,-1)$, $B''(-5,2)$, $C''(-6,-1)$, and $D''(-1,-4)$, but no work is shown.
- [0] A zero response is completely incorrect, irrelevant, or incoherent or is a correct response that was obtained by an obviously incorrect procedure.
-

- [6] A complete and correct proof that includes a concluding statement is written.
- [5] A proof is written that demonstrates a thorough understanding of the method of proof and contains no conceptual errors, but one statement or reason is missing or incorrect, or no concluding statement is written.
- or [5] $\angle A \cong \angle E$ or $\angle B \cong \angle D$ is proven, but no further correct work is shown.
- [4] A proof is written that demonstrates a good understanding of the method of proof and contains no conceptual errors, but two statements or reasons are missing or incorrect.
- or [4] $\triangle ABC \cong \triangle EDC$ is proven, but no further correct work is shown.
- [3] A proof is written that demonstrates a good understanding of the method of proof, but one conceptual error is made.
- [2] Some correct relevant statements about the proof are made, but three or four statements or reasons are missing or incorrect.
- [1] Only one correct statement and reason are written.
- [0] The given and/or the prove statements are rewritten in the style of a formal proof, but no further correct relevant statements are written.
- or [0] A zero response is completely incorrect, irrelevant, or incoherent or is a correct response that was obtained by an obviously incorrect procedure.
-